

MODERN NECESSITIES

Old School Rules For Modern Themes



DESIGNED FOR USE WITH

**OLD-SCHOOL
ESSENTIALS**

By the Scrying Dutchman

MODERN NECESSITIES

DESIGNED FOR USE WITH
**OLD-SCHOOL
ESSENTIALS**

Writing, editing and layout by: The Srying Dutchman

Cover Art by: Geladaa

Interior Art by: Galen Pejeau, Carlos Castilho, Jonathan Torres, Noeland Collins, Geladaa, Adam Black

Proofreaders & Playtesters: Crossface, Kioshi, Tarkeen, The Basic Expert

Special thanks to my family and friends for all the support! Also much thanks to Necrotic Gnome for all the help.



Permission to copy/adapt class abilities and progression tables from Old-School Essentials granted by Necrotic Gnome

Table of Contents

1. Introduction	1	Pharmaceuticals.....	63
2. Classes	3	Demolitions.....	65
Soldier.....	3	7. Vehicles	67
Heavy Gunner.....	6	8. Spells	73
Crook.....	8	9. NPC's	83
Tech Expert.....	11	10. Extra Rules	90
Sniper.....	13		
Survivalist.....	16		
Hired Killer.....	19		
Medic.....	21		
Psychonaut.....	24		
Wheelman.....	26		
Ninja.....	28		
Exorcist.....	31		
Face.....	33		
3. Racial Traits	36		
4. Weapons	38		
Melee Weapons.....	41		
Light Firearms.....	43		
Medium Firearms.....	47		
Heavy Firearms.....	49		
Explosives.....	50		
Firearm Attachments.....	52		
Ammunition.....	54		
5. Armor	56		
6. Equipment	59		
Utilities.....	60		



1. Introduction

Modern Necessities is a continuation of the ideas first developed with the release of Simple Modernity, which aimed to add some quick and dirty rules for modern-day themed play using the B/X ruleset.

Modern Necessities expands on this initial concept by tying it to the actual Old-School Essentials ruleset, streamlining the original efforts while at the same time adding even more content.

By using it alongside OSE and any other compatible books of your choice, Modern Necessities allows you to run your games in a modern-themed setting also of your choice. Mix the contemporary with fantasy to your heart's content! Or even just stick to a more realistic fare.

Even modules can be adapted in this way. Revisit some of the old classics with an AK-47 in hand and a vest full of grenades. Vampire lords and giant dinosaurs won't know what hit them.

Either way, I hope you enjoy the content within, and will keep a look out for future supplements meant to expand this idea into even more thematic areas, from cyberpunk to weird west.

-The Scrying Dutchman





2. Classes

Soldier

- **Requirements:** None
- **Prime requisite:** DEX
- **Hit Dice:** 1d8
- **Maximum Level:** 14
- **Armor:** Any
- **Weapons:** Any
- **Languages:** Alignment, Common, Tactical Hand Signals

Soldiers are the mainstay of any military and mercenary force. They are well trained in basic infantry tactics, as well as being able to learn more advanced skills as they continue their training. In an adventuring party a soldier is perhaps the most flexible combatant, capable of using every type of weapon and armor.

Combat

Soldiers can use all types of weapons and armor, though they are especially comfortable with Assault Rifles and Battle Rifles.

Battle School

Soldiers learn the following skills and abilities during their initial military training. Most of these improve as they level, Grenadier excepted.

- **Rifleman (RM):** Soldiers have a +1 bonus to damage when using Bayonets, Assault Rifles and Battle Rifles.
- **Danger Close (DC):** Soldiers have a +1 to Death saving throws to avoid the effects of Blast weapons.
- **Doorkicker (DK):** Soldiers have a +1 to attempts to open doors using Strength to

a maximum of 5-in-6.

- **Grenadier:** Soldiers have a +10 foot bonus to the throwing ranges of explosives such as frag grenades.

Commando Training

At 6th level, Soldiers are assumed to have undergone additional special training. This gives them the following skills and abilities. Most of these improve as they level, Point Man excepted.

- **Close Quarters (CQ):** Soldiers gain a +1 bonus to damage when using Combat Knives, Sub-Machine Guns and Shotguns.
- **Move Silently (MS):** A Soldier may attempt to sneak past enemies unnoticed.
- **Point Man:** When a Soldier is the first character in a party's marching order, the party gains a +1 on surprise rolls for the purpose of avoiding surprise, as long as the threat comes from the front.

After Reaching 9th Level

A Soldier can now be considered sufficient rank to lead their own unit. This squad will consist out of 1d4 other Soldiers, 1d4 Heavy Gunners and 1d4 Snipers of 1st level. A Soldier might use this unit to start their own mercenary outfit or the like. Should any of these recruits die, the Soldier must seek out replacements.



Soldier Skills Progression					
Level	RM	DC	DK	CQ	MS
1	+1	+1	+1	-	-
2	+1	+1	+1	-	-
3	+1	+1	+1	-	-
4	+1	+1	+1	-	-
5	+2	+1	+1	-	-
6	+2	+1	+1	+1	30
7	+2	+2	+1	+1	35
8	+2	+2	+2	+1	40
9	+3	+2	+2	+2	45
10	+3	+2	+2	+2	55
11	+3	+2	+2	+2	60
12	+3	+2	+2	+3	65
13	+4	+2	+2	+3	70
14	+4	+3	+2	+3	75

Soldier Level Progression			
Level	XP	HD	THACO
1	0	1d8	19 (0)
2	2,000	2d8	19 (0)
3	4,000	3d8	19 (0)
4	8,000	4d8	17 (+2)
5	16,000	5d8	17 (+2)
6	32,000	6d8	17 (+2)
7	64,000	7d8	14 (+5)
8	120,000	8d8	14 (+5)
9	240,000	9d8	14 (+5)
10	360,000	9d8+2*	12 (+7)
11	480,000	9d8+4*	12 (+7)
12	600,000	9d8+6*	12 (+7)
13	720,000	9d8+8*	10 (+9)
14	840,000	9d8+10*	10 (+9)

Soldier Saving Throws					
Level	D	W	P	B	S
1	12	13	14	15	16
2	12	13	14	15	16
3	12	13	14	15	16
4	10	11	12	13	14
5	10	11	12	13	14
6	10	11	12	13	14
7	8	9	10	10	12
8	8	9	10	10	12
9	8	9	10	10	12
10	6	7	8	8	10
11	6	7	8	8	10
12	6	7	8	8	10
13	4	5	6	5	8
14	4	5	6	5	8

*Modifiers to CON no longer apply

D: Death/Poison; **W:** Wands; **P:** Paralysis/Petrify; **B:** Breath Attacks; **S:** Spells/Rods/Staves





Heavy Gunner

- **Requirements:** Minimum CON 9, minimum STR 9
- **Prime requisite:** CON and STR
- **Hit Dice:** 1d10
- **Maximum Level:** 14
- **Armor:** Any
- **Weapons:** Any melee, medium and heavy firearms
- **Languages:** Alignment, Common, Tactical Hand Signals

Heavy Gunners are, as their name implies, heavy weapons experts that prefer firearms that can lay down massive amounts of damage in a short time. What they lack in finesse, they make up for with destructive capability.

Prime Requisites: A Heavy Gunner with at least 13 in one prime requisite gains a 5% bonus to experience. If both STR and CON are 16 or higher, the Heavy Gunner gets a +10% bonus.

Combat

Heavy Gunners prefer weapons that do lots of damage and/or have a large volume of fire.

Machine Gunner

Heavy Gunners have the following skills and abilities. Most of these improve as they level, Gun Shield excepted.

- **Automatic Rifleman (AR):** Heavy Gunners have a +1 bonus to damage when using any type of Auto Fire.
- **Shotgunner (SG):** Heavy Gunners have a +1 bonus to damage when using a weapon with the Spread quality. Additionally, when using firearms with the Spread quality, the chance to hit other enemies within 5 feet of the original target increases to

3-in-6.

- **Gun Shield:** Heavy Gunners gain a +1 bonus to AC and Death saving throws when using heavy firearms.

War Machine

At 6th level, Heavy Gunners have increased their destructive prowess even further. This gives them the following abilities.

- **Bullet Storm:** When using Auto Fire, the radius of a Heavy Gunner's Full-Auto and Suppressive attacks now increases by +5 feet. Additionally, Full-Auto now does Burst damage. Additionally, Heavy Gunners can now also ignore the Slow quality on firearms.
- **Master Blaster:** The radius of weapons using the Blast quality increases by +5 feet, and Blast damage is increased by an additional die. For example, 4d6 damage becomes 5d6 damage. This only applies to weapons that explode immediately upon use by the Heavy Gunner, such as grenades.

After Reaching 9th Level

A Heavy Gunner of 9th level and over is a one man wrecking crew. They gain the choice to raise either CON or STR to 18, if they not already have this score, applying any gain in hit points retroactively if CON is chosen.

Additionally, a Heavy Gunner attracts a single other Heavy Gunner of 2nd level as an assistant gunner. When assisted by this low level Heavy Gunner, the ranges Full-Auto, Suppressive and Spray attacks may be used at increases from short to medium range. While assisting, the assistant gunner may not move or attack, and they must be within 5 feet of the Heavy Gunner.

Should the assistant gunner die, the Heavy Gunner must seek out a replacement.



Machine Gunner Skills Progression		
Level	AR	SG
1	+1	+1
2	+1	+1
3	+1	+1
4	+1	+1
5	+2	+2
6	+2	+2
7	+2	+2
8	+2	+2
9	+3	+3
10	+3	+3
11	+3	+3
12	+3	+3
13	+4	+4
14	+4	+4

Heavy Gunner Level Progression			
Level	XP	HD	THACO
1	0	1d10	19 (0)
2	2,500	2d10	19 (0)
3	5,000	3d10	19 (0)
4	10,000	4d10	17 (+2)
5	18,500	5d10	17 (+2)
6	37,000	6d10	17 (+2)
7	85,000	7d10	14 (+5)
8	140,000	8d10	14 (+5)
9	270,000	9d10	14 (+5)
10	400,000	9d10+4*	12 (+7)
11	530,000	9d10+6*	12 (+7)
12	660,000	9d10+8*	12 (+7)
13	790,000	9d10+10*	10 (+9)
14	920,000	9d10+12*	10 (+9)

Heavy Gunner Saving Throws					
Level	D	W	P	B	S
1	10	13	12	15	16
2	10	13	12	15	16
3	10	13	12	15	16
4	8	11	10	13	13
5	8	11	10	13	13
6	8	11	10	13	13
7	6	9	8	10	10
8	6	9	8	10	10
9	6	9	8	10	10
10	4	7	6	8	7
11	4	7	6	8	7
12	4	7	6	8	7
13	3	5	4	5	5
14	3	5	4	5	5

*Modifiers to CON no longer apply

D: Death/Poison; **W:** Wands; **P:** Paralysis/Petrify; **B:** Breath Attacks; **S:** Spells/Rods/Staves



Crook

- **Requirements:** Minimum DEX 9
- **Prime requisite:** DEX
- **Hit Dice:** 1d6
- **Maximum Level:** 14
- **Armor:** Light Armor
- **Weapons:** Any melee, light and medium firearms
- **Languages:** Alignment, Common

Crooks are career criminals, hustlers, hoodlum, robbers and gangsters. When fighting, their style is very unorthodox and loose, designed to send as many bullets down range as possible with a true 'spray and pray' style. Preferably with a gun in each hand.

Combat

Crooks prefer weapons that can be dual wielded, such as pistols.

Guns Akimbo

Crooks can dual wield one handed weapons and attack with both at the same time. Their off-hand attack takes a -2 penalty to hit however. This is reduced to -1 if dual wield rules are used for every character.

Life of Crime

Crooks have the following skills, useful for conducting their criminal activities. They share these skills with the Thief from official materials.

- **Hear noise (HN):** In a quiet environment (e.g. not in combat), a Crook may attempt to listen at a door or to hear the sounds of something (e.g. a wandering monster) approaching.
- **Move silently (MS):** A Crook may attempt to sneak past enemies

unnoticed.

- **Open locks (OL):** Requires thieves' tools. A Crook can only try this skill once per lock. If the roll fails, the Crook may not try the same lock again before gaining an experience level.
- **Pick pockets (PP):** If the victim is above 5th level, the Crook's roll is penalised by 5% for every level above 5th. There is always at least a 1% chance of failure. A roll of more than twice the percentage required for success means that the attempted theft is noticed. The referee should determine the reaction of the victim.

Way of the Gun

At 6th level, Crooks have perfected their double gun fighting method. This gives them the following abilities.

- **Gun Opera:** The Crook now takes no penalty to hit with their off-hand attacks.
- **Mag Dump:** A Crook may treat a light firearm that does not have Auto Fire as if it does, letting them use Burst, Full-Auto, Suppressive and Spray attacks. After using one of these attacks the Crook must reload the firearm that was used. Alternatively, they may use this ability to give +4 damage to the attacks of a firearm that already has Auto Fire. This also requires them to reload afterwards, once used.

After Reaching 9th Level

A Crook can now set up their own crew to run their own crime ring. They attract 1d6 other Crooks and 1d6 Hired Killers of 1st level to work for them. They can send these criminals and killers out on various missions if they wish, such as hits, burglaries and drug deals. This will earn them extra income, the Crook generally taking a 20% to 30% cut from the illicit proceeds.



Crook Skills Progression				
Level	HN	MS	OL	PP
1	1-2	20	15	20
2	1-2	25	20	25
3	1-3	30	25	30
4	1-3	35	30	35
5	1-3	40	35	40
6	1-3	45	45	45
7	1-4	55	55	55
8	1-4	65	65	65
9	1-4	75	75	75
10	1-4	85	85	85
11	1-5	95	95	95
12	1-5	96	96	105
13	1-5	98	97	115
14	1-5	99	99	125

Crook Level Progression			
Level	XP	HD	THAC0
1	0	1d6	19 (0)
2	2,000	2d6	19 (0)
3	4,000	3d6	19 (0)
4	8,000	4d6	19 (0)
5	16,000	5d6	17 (+2)
6	32,000	6d6	17 (+2)
7	64,000	7d6	17 (+2)
8	120,000	8d6	17 (+2)
9	240,000	9d6	14 (+5)
10	360,000	9d6+2*	14 (+5)
11	480,000	9d6+4*	14 (+5)
12	600,000	9d6+6*	14 (+5)
13	720,000	9d6+8*	12 (+7)
14	840,000	9d6+10*	12 (+7)

Crook Saving Throws					
Level	D	W	P	B	S
1	13	14	13	16	15
2	13	14	13	16	15
3	13	14	13	16	15
4	13	14	13	16	15
5	12	13	11	14	13
6	12	13	11	14	13
7	12	13	11	14	13
8	12	13	11	14	13
9	10	11	9	12	10
10	10	11	9	12	10
11	10	11	9	12	10
12	10	11	9	12	10
13	8	9	7	10	8
14	8	9	7	10	8

*Modifiers to CON no longer apply

D: Death/Poison; **W:** Wands; **P:** Paralysis/Petrify; **B:** Breath Attacks; **S:** Spells/Rods/Staves





Tech Expert

- **Requirements:** Minimum WIS 9, minimum INT 9
- **Prime requisite:** WIS and INT
- **Hit Dice:** 1d4
- **Maximum Level:** 14
- **Armor:** Light Armor
- **Weapons:** Any melee, light firearms
- **Languages:** Alignment, Common, Dark Web Lingo

Tech Experts are professional technicians, comfortable with computers, electronics other technical skills that are rather useful in a support capacity. In some campaign settings they even have knowledge of the arcane in the form of technomancy, magic just being another form of math to them.

Prime Requisites: A Tech Expert with at least 13 in one prime requisite gains a 5% bonus to experience. If both WIS and INT are 16 or higher, the Expert gets a +10% bonus.

Combat

Tech Experts prefer hanging back, letting their more combat oriented team members do the heavy lifting. They use pistols and the like for self defense.

Technomancy

In campaigns with spell casting, or otherwise per referee's discretion, a Tech Expert gets access to a certain number of Technomancy spells. These are stored in their mobile device and the amount is determined by their experience level.

Black Hat

Tech Experts have the following support skills of a technical nature. Most of these improve as they level, Signal Boost excepted.

- **Hacking (HK):** Requires a laptop. A Tech Expert can try to hack different parts of a single system. If the roll fails the next attempt is taken at a -10% penalty. A fail may also trigger security systems and fail safes, per referee's discretion.
- **Find or disable alarms (FA):** A roll is required to find an active, physical alarm system and then another to disable it. This may be attempted only once per alarm.
- **Repair electronic equipment (RE):** Requires a Tool Kit. A Tech Expert can attempt to repair broken or disabled equipment of an electronic nature. If the roll fails, the Tech Expert may not try a repair again before gaining an experience level.
- **Signal Boost:** Whenever a Tech Expert deploys electronic equipment that has a listed effective range, this range is doubled for them.

White Hat

At 6th level, a Tech Expert's technical skills have further improved. They gain the following abilities.

- **Hardwired:** When making a physical, close range connection with a system, hacking attempts gain a +10% bonus.
- **Communications Grid:** Tech Experts can take 12 hours to establish a special, custom communications network between them and their team, should they have access to the proper resources. This grid covers a 10 mile radius in an area of their choice. This grid is highly secure and can not be decrypted or jammed through normal means.

After Reaching 9th Level

A Tech Expert can now set up their own 'Tiger Team' of fellow Tech Experts to provide their services to the highest bidder. This could involve working as criminal hackers, or as so called white hats testing security systems. The Tech Expert attracts 1d6 other Experts of 3rd level for this purpose.

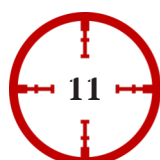

Tech Expert Skills Progression			
Level	HK	FA	RE
1	20	1-2	15
2	25	1-2	20
3	30	1-3	25
4	35	1-3	30
5	40	1-3	35
6	45	1-3	45
7	55	1-4	55
8	65	1-4	65
9	75	1-4	75
10	85	1-4	85
11	90	1-5	95
12	92	1-5	96
13	93	1-5	97
14	94	1-5	99

Tech Expert Technomancy Spells						
Level	1	2	3	4	5	6
1	1	-	-	-	-	-
2	2	-	-	-	-	-
3	2	1	-	-	-	-
4	2	2	-	-	-	-
5	2	2	1	-	-	-
6	2	2	2	-	-	-
7	3	2	2	1	-	-
8	3	2	2	2	-	-
9	3	3	3	2	1	-
10	3	3	3	3	2	-
11	4	3	3	3	2	1
12	4	3	3	3	3	2
13	4	4	4	3	3	3
14	4	4	4	4	3	3

Tech Expert Level Progression			
Level	XP	HD	THACO
1	0	1d4	19 (0)
2	2,500	2d4	19 (0)
3	5,000	3d4	19 (0)
4	10,000	4d4	19 (0)
5	20,000	5d4	19 (0)
6	40,000	6d4	17 (+2)
7	80,000	7d4	17 (+2)
8	150,000	8d4	17 (+2)
9	300,000	9d4	17 (+2)
10	450,000	9d4+1*	17 (+2)
11	600,000	9d4+2*	14 (+5)
12	750,000	9d4+3*	14 (+5)
13	900,000	9d4+4*	14 (+5)
14	1,050,000	9d4+5*	14 (+5)

Tech Expert Saving Throws					
Level	D	W	P	B	S
1	13	14	13	16	15
2	13	14	13	16	15
3	13	14	13	16	15
4	13	14	13	16	15
5	13	14	13	16	15
6	11	12	11	14	12
7	11	12	11	14	12
8	11	12	11	14	12
9	11	12	11	14	12
10	11	12	11	14	12
11	8	9	8	11	8
12	8	9	8	11	8
13	8	9	8	11	8
14	8	9	8	11	8

*Modifiers to CON no longer apply

D: Death/Poison; **W:** Wands; **P:** Paralysis/Petrify; **B:** Breath Attacks; **S:** Spells/Rods/Staves



Sniper

- **Requirements:** Minimum WIS 9
- **Prime requisite:** WIS
- **Hit Dice:** 1d6
- **Maximum Level:** 14
- **Armor:** Light armor
- **Weapons:** Any
- **Languages:** Alignment, Common, Tactical Hand Signals

Snipers are expert marksmen dedicated to that one, perfect long range shot. They are trained to take out their prey from concealment, taking out valuable targets and spreading terror and uncertainty on the battlefield.

Combat

Snipers prefer taking out enemies at a reasonable distance, preferably while set up in a position of concealment and cover. They carry light weapons for self defense in a pinch.

Scout Sniper

Snipers have undergone special training to make them effective at stealth and scouting. This gives them the following abilities. Some of these improve as they level.

- **Ghillie Suit:** A sniper can take 30 minutes to construct a special camouflage suit matching the area they are in, usually natural or urban ruin. A ghillie suited sniper can hide in the environment matching their suit, such as undergrowth or rubble, with a 90% chance of success.
- **Pathfinder:** A sniper can pass through natural environments with a 90% chance to not leave any tracks. The Sniper is also able to move through overgrown areas at normal speed and without impediment.
- **Move silently (MS):** A Sniper may attempt to sneak past enemies unnoticed.
- **Sniping (SP):** A sniper has a 25% chance to stay hidden when they fire from concealment. Every subsequent shot decreases this chance by -10%. They must be using a weapon with the Sniper property and be firing from medium range or long range. A suppressor reduces the penalty to -5%.

Death From Afar

At 6th level, Snipers are a true terror with a rifle. This gives them the following abilities. Counter Sniper improves as they level.

- **Bad For Morale:** Whenever a Sniper kills a creature from hiding without being discovered, the other enemy creatures in combat have their morale score reduced by -1. This only applies to creatures with a morale score below 12.
- **Long Distance Shooter:** A Sniper can gain the benefit of spending a round to aim a weapon with the Sniper quality twice before re-aiming.
- **Counter Sniper (CS):** A Sniper gains +1 damage against enemy creatures using weapons with the Sniper quality.

After Reaching 9th Level

At 9th level, a Sniper may take a spotter with them into the field. This spotter can be another Sniper, or a Soldier, of 3rd level. When this spotter is within 5 feet of the Sniper they may use their round to help them target a single enemy creature at medium and long range. When attacking the spotted creature, this allows the Sniper to make an additional attack roll and pick the best result to try and score a hit. If the Spotter is hit during the spotting round the Sniper does not gain this benefit until the Spotter successfully tries again.



Sniper Skills Progression			
Level	MS	SP	CS
1	15	25	-
2	20	30	-
3	25	35	-
4	30	40	-
5	35	45	-
6	45	50	+1
7	55	55	+1
8	65	60	+1
9	75	65	+2
10	85	70	+2
11	90	75	+2
12	95	80	+3
13	97	85	+3
14	99	90	+3

Sniper Level Progression			
Level	XP	HD	THACO
1	0	1d6	19 (0)
2	2,500	2d6	19 (0)
3	5,000	3d6	19 (0)
4	10,000	4d6	17 (+2)
5	18,500	5d6	17 (+2)
6	37,000	6d6	17 (+2)
7	85,000	7d6	14 (+5)
8	140,000	8d6	14 (+5)
9	270,000	9d6	14 (+5)
10	400,000	9d6+2*	12 (+7)
11	530,000	9d6+4*	12 (+7)
12	660,000	9d6+6*	12 (+7)
13	790,000	9d6+8*	10 (+9)
14	920,000	9d6+10*	10 (+9)

Sniper Saving Throws					
Level	D	W	P	B	S
1	12	13	14	15	16
2	12	13	14	15	16
3	12	13	14	15	16
4	10	11	12	13	14
5	10	11	12	13	14
6	10	11	12	13	14
7	8	9	10	10	12
8	8	9	10	10	12
9	8	9	10	10	12
10	6	7	8	8	10
11	6	7	8	8	10
12	6	7	8	8	10
13	4	5	6	5	8
14	4	5	6	5	8

*Modifiers to CON no longer apply

D: Death/Poison; **W:** Wands; **P:** Paralysis/Petrify; **B:** Breath Attacks; **S:** Spells/Rods/Staves





Survivalist

- **Requirements:** Minimum WIS 9
- **Prime requisite:** WIS
- **Hit Dice:** 1d6
- **Maximum Level:** 14
- **Armor:** Light armor
- **Weapons:** Any
- **Languages:** Alignment, Common

Survivalists are quite comfortable out in the wilderness, living off the grid, experts in self reliance. They are a quite useful addition to any team working out in the wilds.

Combat

Survivalists prefer reasonably light, portable armor and weapons that let them easily move around rough terrain. Their choice of firearms tend to be suitable for hunting and scouting purposes.

Bushcraft

Survivalists are, as their name implies, quite adept at survival. This gives them the following abilities. Ambusher and Tracking improve as they level.

- **Ambusher (AM):** When successfully laying in wait and surprising an enemy, a Survivalist has a +2 bonus to damage on their first turn when using the Magnum Pistol/Revolver, any Shotgun or the Hunting Rifle at close range.
- **Foraging and Hunting:** A party with a Survivalist can more easily find food when foraging (2-in-6) or prey when hunting (5-in-6).
- **Escape & Evasion:** When the Survivalist's party is pursued by an opposing group in the wilderness, the chance of evasion is increased by 10%.

When the Survivalist's party pursues an opposing group in the wilderness themselves, their chance of evasion is reduced by 10%.

- **Tracking (TR):** Survivalists can identify and follow tracks. This skill improves as the character gains levels. Success may be modified by the following factors:
 - **Soft/hard ground:** +20% to -50%.
 - **Size of group being tracked:** +2% per creature beyond the first.
 - **Passing through an area where other tracks mingle:** -50%.
 - **Age of tracks:** -5% per 12 hours.
 - **Rainfall:** -25% per hour.
 - **Efforts made to hide tracks:** -25%.

Prepper

At 6th level, a Survivalist is always prepared. This gives them the following abilities. Reloader and Canning improve as they level.

- **Reloader (RL):** A Survivalist has access to portable ammo reloading equipment. Once a day, they may make 1d6 reloads for any bullet or shotgun ammo firearm. This takes 1 hour. They may only create common ammunition.
- **Canning (CN):** Once a day, a Survivalist may make 1d6 rations from any food they successfully hunted and foraged. This takes 2 hours.
- **Rationing:** A Survivalist can make a party's rations last twice as long. However, a character on rationing will be weaker and take a -1 penalty to their natural healing rolls.

After Reaching 9th Level

At 9th level, a Survivalist can now establish their own survival compound in a wilderness location of their choice. This fortified compound (which can include an underground bunker) has all the means for a party of up to 12 people to survive indefinitely. Additionally, when staying at this compound, the 6th level Reloader and Canning abilities result in three times the yield when used.



Survivalist Skills Progression				
Level	AM	TR	RL	CN
1	+2	20	-	-
2	+2	30	-	-
3	+2	40	-	-
4	+3	50	-	-
5	+3	60	-	-
6	+3	70	1d6+1	1d6+1
7	+4	80	1d6+1	1d6+1
8	+4	90	1d6+2	1d6+1
9	+4	100	1d6+2	1d6+2
10	+4	110	1d6+3	1d6+2
11	+5	110	1d6+3	1d6+2
12	+5	110	1d6+4	1d6+3
13	+5	110	1d6+4	1d6+3
14	+5	110	1d6+5	1d6+4

Survivalist Level Progression			
Level	XP	HD	THAC0
1	0	1d6	19 (0)
2	2,250	2d6	19 (0)
3	4,500	3d6	19 (0)
4	10,000	4d6	17 (+2)
5	20,000	5d6	17 (+2)
6	40,000	6d6	17 (+2)
7	90,000	7d6	14 (+5)
8	150,000	8d6	14 (+5)
9	300,000	9d6	14 (+5)
10	425,000	9d6+2*	12 (+7)
11	550,000	9d6+4*	12 (+7)
12	675,000	9d6+6*	12 (+7)
13	800,000	9d6+8*	10 (+9)
14	925,000	9d6+10*	10 (+9)

Survivalist Saving Throws					
Level	D	W	P	B	S
1	12	13	14	15	16
2	12	13	14	15	16
3	12	13	14	15	16
4	10	11	12	13	14
5	10	11	12	13	14
6	10	11	12	13	14
7	8	9	10	10	12
8	8	9	10	10	12
9	8	9	10	10	12
10	6	7	8	8	10
11	6	7	8	8	10
12	6	7	8	8	10
13	4	5	6	5	8
14	4	5	6	5	8

*Modifiers to CON no longer apply

D: Death/Poison; **W:** Wands; **P:** Paralysis/Petrify; **B:** Breath Attacks; **S:** Spells/Rods/Staves





Hired Killer

- **Requirements:** Minimum DEX 9
- **Prime requisite:** DEX
- **Hit Dice:** 1d6
- **Maximum Level:** 14
- **Armor:** Light armor
- **Weapons:** Any melee, light and medium firearms
- **Languages:** Alignment, Common

Hired Killers are the ones that are called when someone simply needs to go away. They generally work for criminal factions or even government agencies as freelancers.

Combat

Hired Killers rely more on stealth than direct conflict. They prefer light-weight armor that lets them sneak around, and close range weapons for an intimate kill.

Professional

Hired Killers are masters of the close range kill. This gives them the following abilities. All of these improve as they level.

- **Assassination (AS):** When attacking an unaware humanoid from behind, a Hired killer gains a +4 bonus to hit with melee weapons, and a +2 bonus to hit with firearms as long as the attack is made within 20 feet and with single shots. If the attack succeeds, the victim must **save vs. Death** with a penalty dependent on the Hired Killer's level. If the save fails, the victim is instantly killed; otherwise the Hired killer's attack inflicts normal damage. A Hired Killer can Assassinate humans/demihumans of any level and humanoid monsters of up to 4+1 HD. Non-living creatures are immune.

- **Hear noise (HN):** In a quiet environment (e.g. not in combat), a Hired Killer may attempt to listen at a door or to hear the sounds of something (e.g. a wandering monster) approaching.
- **Hide in shadows (HS):** Requires the Hired Killer to be motionless. Attacking while hiding is not possible until 6th level.
- **Move silently (MS):** A Hired Killer may attempt to sneak past enemies unnoticed.
- **Gray Man (GM):** A Hired Killer can blend into a crowd. As long as they are surrounded by a sufficient amount of every day civilians and they do not act or look obviously suspicious, opponents looking for them only have a 30% chance to spot them if aware of their appearance.

Killer Elite

At 6th level, Hired Killers are at the top of their game when it comes to the art of murder. This gives them the following abilities.

- **Double Tap:** When using a firearm to perform an assassination, and if the target has survived the first shot, the Hired Killer can make another attack right after with a -4 penalty to deal normal damage.
- **Knife in the Dark:** When a Hired Killer uses **Hide in Shadows**, they may now attack with melee weapons if an unaware enemy passes them within range, including the ability to assassinate if they can attack from behind.

After Reaching 9th Level

At 9th level, a Hired Killer can act as a broker for other, lower level killers. They attract 2d6 other Hired Killers of 1st level, which can be sent out on their own missions (to be discussed with the referee) or taken on the character's missions. The Hired Killer takes a 30% cut of the proceeds of these missions.



Hired Killer Skills Progression					
Level	AS	HN	HS	MS	GM
1	0	1-2	10	20	30
2	0	1-2	15	25	30
3	0	1-3	20	30	30
4	-1	1-3	25	35	25
5	-1	1-3	30	40	25
6	-2	1-3	33	43	25
7	-2	1-4	36	46	20
8	-3	1-4	40	50	20
9	-3	1-4	43	53	20
10	-4	1-4	46	56	15
11	-4	1-5	50	60	15
12	-5	1-5	53	63	15
13	-5	1-5	56	66	10
14	-6	1-5	60	70	10

Hired Killer Level Progression			
Level	XP	HD	THACO
1	0	1d6	19 (0)
2	2,000	2d6	19 (0)
3	4,000	3d6	19 (0)
4	8,000	4d6	19 (0)
5	16,000	5d6	17 (+2)
6	32,000	6d6	17 (+2)
7	64,000	7d6	17 (+2)
8	120,000	8d6	17 (+2)
9	240,000	9d6	14 (+5)
10	360,000	9d6+2*	14 (+5)
11	480,000	9d6+4*	14 (+5)
12	600,000	9d6+6*	14 (+5)
13	720,000	9d6+8*	12 (+7)
14	840,000	9d6+10*	12 (+7)

Hired Killer Saving Throws					
Level	D	W	P	B	S
1	13	14	13	16	15
2	13	14	13	16	15
3	13	14	13	16	15
4	13	14	13	16	15
5	12	13	11	14	13
6	12	13	11	14	13
7	12	13	11	14	13
8	12	13	11	14	13
9	10	11	9	12	10
10	10	11	9	12	10
11	10	11	9	12	10
12	10	11	9	12	10
13	8	9	7	10	8
14	8	9	7	10	8

*Modifiers to CON no longer apply

D: Death/Poison; **W:** Wands; **P:** Paralysis/Petrify; **B:** Breath Attacks; **S:** Spells/Rods/Staves



Medic

- **Requirements:** Minimum WIS 9, minimum INT 9
- **Prime requisite:** WIS and INT
- **Hit Dice:** 1d6
- **Maximum Level:** 14
- **Armor:** Any
- **Weapons:** Any melee, light and medium firearms
- **Languages:** Alignment, Common

Medics are trained in battlefield medicine as well as aftercare, capable of patching up their comrades after a harsh gunbattle and making sure they heal up properly.

Prime Requisites: A Medic with at least 13 in one prime requisite gains a 5% bonus to experience. If both WIS and INT are 16 or higher, the Medic gets a +10% bonus.

Combat

Medics can use all types of armor. However, they prefer light weight weapons that allow them to quickly move to a fallen ally.

Healing Magic

In campaigns with spell casting, or otherwise per referee's discretion, a Medic gets access to a certain number of divine spells. Also per referee's discretion these may only be spells considered thematically appropriate for a Medic. The amount is determined by their experience level.

Field Medicine

Medics can provide advanced medical care to the party. This gives them the following abilities. Urgent Care and Bedside Care improve as they level.

- **Urgent Care (UC):** When medics heal a wounded ally in any way during the adventuring phase, they add a +1 to the amount the ally is healed. This cannot grant more hit points than the normal maximum.
- **Bedside Care (BC):** When completely resting together with their allies in close proximity (must all share the same quarters) the medic and their allies can regain 1d6 hit points a day instead of 1d3. Every two days of this type of rest consumes 1 med kit. If only one day of Bedside Care is used the healing effectiveness of 1 med kit is cut in half.
- **CPR:** Medics have a 3-in-6 chance to bring a dead character back to life if they have been dead for no more than a minute (and their body is reasonably intact), bringing them back to 1 hit point. They may only attempt this once per dead character.

Pharmacist

At 6th level, a Medic can mix their own medicine and drugs in the field, using ingredients from med kits. This takes 1 hour. They may take it apart a med kit to make the following

- 1d4 **Antidote**
- 2d4 **Stimulants**
- 1d6 **Stimulant Darts** (Can be loaded in pistol or revolver, -2 to hit)

When using a military med kit to do this instead, the numbers are increased by +2d4 for each option.

After Reaching 9th Level

At 9th level, a Medic can now set up a field hospital or private clinic in a location of their choice. They attract 1d6 other Medics of 3rd level to help staff this hospital. Resting in this hospital doubles the Hit Points a character regains from natural healing each day. This hospital may even be a source of income for the Medic, as they provide medical care to the local populace. Ownership of this hospital additionally provides them a 25% discount on any medical items.



Medic Skills Progression		
Level	UC	BC
1	+1	1d4
2	+1	1d4
3	+1	1d4
4	+1	1d4
5	+2	1d6
6	+2	1d6
7	+2	1d6
8	+2	1d6
9	+3	1d8
10	+3	1d8
11	+3	1d8
12	+3	1d8
13	+4	1d10
14	+4	1d10

Medic Divine Spells					
Level	1	2	3	4	5
1	-	-	-	-	-
2	1	-	-	-	-
3	2	-	-	-	-
4	2	1	-	-	-
5	2	2	-	-	-
6	2	2	1	1	-
7	2	2	2	1	1
8	3	3	2	2	1
9	3	3	3	2	2
10	4	4	3	3	2
11	4	4	4	3	3
12	5	5	4	4	3
13	5	5	5	4	4
14	6	5	5	5	4

Medic Level Progression			
Level	XP	HD	THAC0
1	0	1d6	19 (0)
2	1,500	2d6	19 (0)
3	3,000	3d6	19 (0)
4	6,000	4d6	19 (0)
5	12,000	5d6	17 (+2)
6	25,000	6d6	17 (+2)
7	50,000	7d6	17 (+2)
8	100,000	8d6	17 (+2)
9	200,000	9d6	14 (+5)
10	300,000	9d6+2*	14 (+5)
11	400,000	9d6+4*	14 (+5)
12	500,000	9d6+6*	14 (+5)
13	600,000	9d6+8*	12 (+7)
14	700,000	9d6+10*	12 (+7)

Medic Saving Throws					
Level	D	W	P	B	S
1	11	12	14	16	15
2	11	12	14	16	15
3	11	12	14	16	15
4	11	12	14	16	15
5	9	10	12	14	12
6	9	10	12	14	12
7	9	10	12	14	12
8	9	10	12	14	12
9	6	7	9	11	9
10	6	7	9	11	9
11	6	7	9	11	9
12	6	7	9	11	9
13	3	5	7	8	7
14	3	5	7	8	7

*Modifiers to CON no longer apply

D: Death/Poison; **W:** Wands; **P:** Paralysis/Petrify; **B:** Breath Attacks; **S:** Spells/Rods/Staves



Psychonaut

- **Requirements:** Minimum INT 9
- **Prime requisite:** INT
- **Hit Dice:** 1d4
- **Maximum Level:** 14
- **Armor:** Light armor
- **Weapons:** Any melee, light firearms
- **Languages:** Alignment, Common

Psychonauts are trained in the use of strange magics that are fueled by the use of psychedelic drugs. This ability could have been the result of some secret government program, or perhaps simply a consequence of delving too deep into some new age religion.

Combat

Psychonauts wear light armor. Additionally, their training with weapons is minimal, only able to use handguns and the like with any effectiveness.

Magic Trip

Psychonauts memorize arcane spells at the beginning of each day by ingesting psychedelic drugs and going into a trance for at least 10 minutes. They gain these spells by communicating with interdimensional entities of their choice, such as Clockwork Elves. The amount is determined by their experience level.

Third Eye

Psychonauts can also take psychedelic drugs to open up their third eye, giving them the following abilities.

- **High Tolerance:** A Psychonaut can take a normal dose of psychedelic drugs without suffering the usual ill effects, such as hallucinations. An additional dose has a 1-in-6 chance of affecting them. Any dose after this increases this chance by 1.

- **Astral Projection (AP):** A Psychonaut can take a single dose of psychedelic drugs at any point to astral project, allowing their spirit to explore in a 100 foot radius around their body for 1 turn. This includes the ability to go through solid walls and doors. They cannot willingly exit the astral plane during this time. They may use this ability to scout ahead and snoop on unaware persons. Only other Psychonauts and creatures with psychic abilities have a 3-in-6 chance of becoming aware of their spirit's presence. If the drugs they took are affecting them despite their **High Tolerance**, there is also a 2-in-6 chance psychic monsters will be present in this astral plane. The amount of time and the radius they can explore increases as they level. Even at higher levels they must still spend at least 10 minutes on the astral plane before they may leave again.

Veteran of the Psychic Wars

At 6th level, a Psychonaut encountering a psychic monster upon the astral plane has a +1 bonus to attack and to damage when engaging them in combat. Additionally, they may attempt to physically attack creatures in the real world. Attacks on physical creatures must be made at melee range with a -6 penalty and only cause subdual damage. Physical creatures may not retaliate unless they are also Psychonauts or otherwise possess psychic abilities.

After Reaching 9th Level

At 9th level, a Psychonaut has access to their own safe area with a sensory deprivation tank. While Astral Projecting from this tank, they can stay upon the astral plane indefinitely, leave whenever they wish, and can travel it at any distance. They may use this ability to spy on unaware persons, perform advanced magical research by communicating with strange entities, root out the secrets of the multiverse, or any other flavorful use they and the referee may be able to come up with. They also attract 1d6 1st level Psychonauts to be their acolytes.



Psychonaut Skills Progression		
Level	AP duration	AP radius
1	10	100 ft
2	15	200 ft
3	20	300 ft
4	25	400 ft
5	30	500 ft
6	40	600 ft
7	50	700 ft
8	60	800 ft
9	70	900 ft
10	80	1000 ft
11	90	1100 ft
12	100	1200 ft
13	110	1300 ft
14	120	1400 ft

Psychonaut Arcane Spells						
Level	1	2	3	4	5	6
1	1	-	-	-	-	-
2	2	-	-	-	-	-
3	2	1	-	-	-	-
4	2	2	-	-	-	-
5	2	2	1	-	-	-
6	2	2	2	-	-	-
7	3	2	2	1	-	-
8	3	2	2	2	-	-
9	3	3	3	2	1	-
10	3	3	3	3	2	-
11	4	3	3	3	2	1
12	4	3	3	3	3	2
13	4	4	4	3	3	3
14	4	4	4	4	3	3

Psychonaut Level Progression			
Level	XP	HD	THAC0
1	0	1d4	19 (0)
2	2,500	2d4	19 (0)
3	5,000	3d4	19 (0)
4	10,000	4d4	19 (0)
5	20,000	5d4	19 (0)
6	40,000	6d4	17 (+2)
7	80,000	7d4	17 (+2)
8	150,000	8d4	17 (+2)
9	300,000	9d4	17 (+2)
10	450,000	9d4+1*	17 (+2)
11	600,000	9d4+2*	14 (+5)
12	750,000	9d4+3*	14 (+5)
13	900,000	9d4+4*	14 (+5)
14	1,050,000	9d4+5*	14 (+5)

Psychonaut Saving Throws					
Level	D	W	P	B	S
1	12	13	14	15	16
2	12	13	14	15	16
3	12	13	14	15	16
4	10	11	12	13	14
5	10	11	12	13	14
6	10	11	12	13	14
7	8	9	10	10	12
8	8	9	10	10	12
9	8	9	10	10	12
10	6	7	8	8	10
11	6	7	8	8	10
12	6	7	8	8	10
13	4	5	6	5	8
14	4	5	6	5	8

*Modifiers to CON no longer apply

D: Death/Poison; **W:** Wands; **P:** Paralysis/Petrify; **B:** Breath Attacks; **S:** Spells/Rods/Staves



Wheelman

- **Requirements:** Minimum DEX 9
- **Prime requisite:** DEX
- **Hit Dice:** 1d8
- **Maximum Level:** 14
- **Armor:** Any
- **Weapons:** Any melee, light and medium firearms
- **Languages:** Alignment, Common

Wheelmen are expert drivers and mechanics, able to operate a wide variety of vehicles with ease. They are a valuable member of any modern team of professionals.

Combat

Wheelmen can use all types of armor. However, they prefer fairly portable firearms, easily stowed in the passenger seat of whatever vehicle they are operating.

Driver

A wheelman's experience with handling vehicles gives them the following abilities. All of these improve as they level.

- **Speed Demon (SP):** A Wheelman can operate any vehicle with a +10% bonus to its maximum movement rate.
- **Grease Monkey (GM):** When repairing a vehicle with a Wheelman taking the lead, repairs restore 2 Hull Points per turn instead of 1. Requires a tool kit or workshop.
- **Gone In 60 Seconds (GS):** A Wheelman can attempt to successfully break into and hotwire vehicles that do not belong to them. This requires thieves' tools. A roll is required to break into the vehicle and then another to hotwire it.

Expert Driver

At 6th level, a Wheelman has further improved their expertise with vehicles. This gives them the following abilities.

- **Wrecker:** A Wheelman does double damage against other vehicles. Additionally, if a vehicle they are operating crashes they and their passengers only take half falling damage, rounded down.
- **Tactical Driving:** A Wheelman only loses half maneuverability when operating a vehicle and performing a non-linear movement, rounded down.
- **Vanishing Point:** When pursued by another vehicle, the chance of evasion can never be lower than 50% as long as the Wheelman is operating the pursued vehicle.

After Reaching 9th Level

At 9th level, a Wheelman own their own fleet of vehicles. This fleet consists out of 1d6 Land Vehicles, 1d6 Air Vehicles and 1d6 Water Vehicles. This includes the space(s) to keep them, such as in a garage and a small, private airport and marina in suitable locations of the Wheelman's choice. These locations have the full facilities to maintain these vehicles, including staff. Additionally, due to their connections, the Wheelman gets a 25% discount when purchasing any additional vehicles.



Wheelman Skills Progression			
Level	SP	GM	GS
1	10	2	15
2	10	2	20
3	10	2	25
4	15	3	30
5	15	3	35
6	15	3	45
7	20	4	55
8	20	4	65
9	20	4	75
10	25	5	85
11	25	5	95
12	25	5	96
13	30	6	97
14	30	6	99

Wheelman Level Progression			
Level	XP	HD	THAC0
1	0	1d8	19 (0)
2	2,000	2d8	19 (0)
3	4,000	3d8	19 (0)
4	8,000	4d8	17 (+2)
5	16,000	5d8	17 (+2)
6	32,000	6d8	17 (+2)
7	64,000	7d8	14 (+5)
8	120,000	8d8	14 (+5)
9	240,000	9d8	14 (+5)
10	360,000	9d8+2*	12 (+7)
11	480,000	9d8+4*	12 (+7)
12	600,000	9d8+6*	12 (+7)
13	720,000	9d8+8*	10 (+9)
14	840,000	9d8+10*	10 (+9)

Wheelman Saving Throws					
Level	D	W	P	B	S
1	12	13	14	15	16
2	12	13	14	15	16
3	12	13	14	15	16
4	10	11	12	13	14
5	10	11	12	13	14
6	10	11	12	13	14
7	8	9	10	10	12
8	8	9	10	10	12
9	8	9	10	10	12
10	6	7	8	8	10
11	6	7	8	8	10
12	6	7	8	8	10
13	4	5	6	5	8
14	4	5	6	5	8

*Modifiers to CON no longer apply

D: Death/Poison; **W:** Wands; **P:** Paralysis/Petrify; **B:** Breath Attacks; **S:** Spells/Rods/Staves

Ninja

- **Requirements:** Minimum DEX 9
- **Prime requisite:** DEX
- **Hit Dice:** 1d6
- **Maximum Level:** 14
- **Armor:** Light armor
- **Weapons:** Any melee, non-firearm missile weapons
- **Languages:** Alignment, Common

Ninjas are masters of stealth, assassination and martial arts. While rare in modern times, they continue to operate from the shadows, their clans often tied to equally ancient organized crime groups.

Combat

Ninjas wear light armor that allows them to remain stealthy. Ninjas prefer the more archaic melee and thrown weaponry of their deadly art.

Ninjutsu

Ninjas are masters of martial arts and unconventional tactics. This gives them the following abilities. Most of these improve as they level, Stealth Killer excepted.

- **Stealth Killer:** When attacking an unaware opponent from behind, or during their first turn after gaining surprise, a Ninja has a +4 bonus to hit with melee weapons, unarmed and thrown weapons such as knives.
- **Empty Hand (EH):** A Ninja's unarmed attacks do 1d4 damage, with additional bonuses as they level.
- **Climb sheer surfaces (CS):** A roll is required for each 100' to be climbed. If the roll fails, the Ninja falls at the halfway point, suffering falling damage.

- **Hear noise (HN):** In a quiet environment (e.g. not in combat), a Ninja may attempt to listen at a door or to hear the sounds of something (e.g. a wandering monster) approaching.
- **Move silently (MS):** A Ninja may attempt to sneak past enemies unnoticed.
- **Open locks (OL):** Requires thieves' tools. A Ninja can only try this skill once per lock. If the roll fails, the Ninja may not try the same lock again before gaining an experience level.
- **Hide in shadows (HS):** The Ninja can move at 1/3rd their normal rate while hiding in shadows, and may attack with melee weapons or unarmed.
- **Deflect Missiles:** A Ninja can make a **save vs. Spells** to deflect missiles such as thrown knives and arrows. A 19 or 20 on the roll allows them to catch the missile instead. The caught missile may be thrown as a missile weapon with a range of 20/30/40 and the damage of the parent weapon.

Ninja Master

At 6th level, a Ninja's skill at stealth and martial arts becomes almost superfluous. This gives them the following abilities.

- **Improved Deflect Missiles:** A Ninja can make a **save vs. Spells** to deflect (not catch) bullets fired from single shot firearms as long as they are holding a melee weapon.
- **Shadow Warrior:** A Ninja may now move at half their normal rate while hiding in shadows.

After Reaching 9th Level

At 9th level, a Ninja may attempt to take over their clan by killing the grand master. Other members of the clan will oppose this aim and attempt to fight the Ninja in turn. Should they succeed in killing the grand master however, the surviving members will accept the Ninja's rule.



Ninja Skills Progression						
Level	EH	CS	HN	MS	OL	HS
1	0	87	1-2	25	15	20
2	0	88	1-2	30	20	25
3	+1	89	1-3	35	25	30
4	+1	90	1-3	40	30	35
5	+1	91	1-3	45	35	40
6	+2	92	1-3	55	40	45
7	+2	93	1-4	65	45	55
8	+2	94	1-4	75	55	65
9	+3	95	1-4	85	65	75
10	+3	96	1-4	95	75	85
11	+3	97	1-5	96	85	95
12	+4	98	1-5	97	95	96
13	+4	99	1-5	98	97	98
14	+4	99	1-5	99	99	99

Ninja Level Progression			
Level	XP	HD	THACO
1	0	1d6	19 (0)
2	2,250	2d6	19 (0)
3	4,500	3d6	19 (0)
4	10,000	4d6	19 (0)
5	20,000	5d6	17 (+2)
6	40,000	6d6	17 (+2)
7	90,000	7d6	17 (+2)
8	150,000	8d6	17 (+2)
9	300,000	9d6	14 (+5)
10	425,000	9d6+2*	14 (+5)
11	550,000	9d6+4*	14 (+5)
12	675,000	9d6+6*	14 (+5)
13	800,000	9d6+8*	12 (+7)
14	925,000	9d6+10*	12 (+7)

Ninja Saving Throws					
Level	D	W	P	B	S
1	13	14	13	16	15
2	13	14	13	16	15
3	13	14	13	16	15
4	13	14	13	16	15
5	12	13	11	14	13
6	12	13	11	14	13
7	12	13	11	14	13
8	12	13	11	14	13
9	10	11	9	12	10
10	10	11	9	12	10
11	10	11	9	12	10
12	10	11	9	12	10
13	8	9	7	10	8
14	8	9	7	10	8

*Modifiers to CON no longer apply

D: Death/Poison; **W:** Wands; **P:** Paralysis/Petrify; **B:** Breath Attacks; **S:** Spells/Rods/Staves



Exorcist

- **Requirements:** Minimum WIS 9
- **Prime requisite:** WIS
- **Hit Dice:** 1d6
- **Maximum Level:** 14
- **Armor:** Any
- **Weapons:** Any
- **Languages:** Alignment, Common

Exorcists are professional hunters of things that go bump in the night, from demons to vampires and other supernatural creatures posing a threat to the innocent. They most often work for secret orders.

Combat

Exorcists can wear any armor and use any weapon they see fit. They tailor their equipment to whatever threat they think they may face at the time.

Force For Good

In campaigns with spell casting, or otherwise per referee's discretion, a Exorcists gets access to a certain number of divine spells. They must carry a symbol of their faith or the organization empowering them. The amount is determined by their experience level.

Monster Hunter

As professional monster hunters, Exorcists gain the following abilities. Resist Evil and Silver Bullet improve as they level.

- **Resist Evil (RE):** Exorcists takes -1 damage from evil supernatural creatures (referee's discretion).
- **Silver Bullet (SB):** Once a day, the Exorcist may use any silver pieces (SP) they have on them to turn existing ammo they have into silver

ammo. Every 300 silver pieces used allows them to silver a certain amount of reloads based on their level.

- **Demonology:** Exorcists often have special knowledge of fiends and other supernatural threats due to their studies. Per referee's discretion, they may know some of the special abilities and weaknesses of monsters encountered, even on a first time encounter.

Battle Exorcist

At 6th level, the Exorcist's abilities to vanquish the supernatural strikes fear in any monster's heart. This gives them the following abilities.

- **Sin Eater:** When targeted by a spell from an evil supernatural creature the Exorcist has a +2 bonus to any saving throw related to resisting the magic. On a roll of 20 they also gain a spell slot equal to -1 the level of the spell cast against them, to be used with their already memorized spells.
- **Turn Undead:** The Exorcist gains the ability to turn undead equal to a Cleric of 3rd level. This ability continues to improve from there on out (7th level Exorcist gains 4th level Turn Undead, etc).
- **Anathema:** The Exorcist can bless a number of weapons a day, making them +1 magic weapons when attacking an evil supernatural creature. They can bless an amount of weapons equal to their Wisdom modifier.

After Reaching 9th Level

An Exorcist can establish a cell of their order (or start their own small organization if unaffiliated) in a fortified, hallowed location of their choice. This could be a church, temple or other suitable location within an area they wish to protect. If unhallowed, the Exorcist can find someone to consecrate the location. The Exorcist then proceeds to attract 1d6 2nd level Exorcists to their cause, as well as an amount of other classes of their choice at 2nd level, equal to their Wisdom modifier.

Exorcist Skills Progression		
Level	RE	SB
1	-1	1 reload
2	-1	1 reload
3	-1	1 reload
4	-1	2 reloads
5	-2	2 reloads
6	-2	2 reloads
7	-2	3 reloads
8	-2	3 reloads
9	-3	3 reloads
10	-3	4 reloads
11	-3	4 reloads
12	-3	4 reloads
13	-4	5 reloads
14	-4	5 reloads

Exorcist Divine Spells					
Level	1	2	3	4	5
1	1	-	-	-	-
2	1	-	-	-	-
3	2	-	-	-	-
4	2	1	-	-	-
5	2	2	1	-	-
6	2	2	1	1	-
7	2	2	2	1	-
8	3	2	2	2	-
9	3	3	3	2	1
10	4	3	3	2	1
11	4	3	3	2	2
12	4	4	3	3	3
13	5	4	4	3	3
14	6	5	4	4	4

Exorcist Level Progression			
Level	XP	HD	THACO
1	0	1d6	19 (0)
2	2,500	2d6	19 (0)
3	5,000	3d6	19 (0)
4	10,000	4d6	19 (0)
5	20,000	5d6	19 (0)
6	40,000	6d6	17 (+2)
7	80,000	7d6	17 (+2)
8	150,000	8d6	17 (+2)
9	300,000	9d6	14 (+5)
10	450,000	9d6+2*	14 (+5)
11	600,000	9d6+4*	14 (+5)
12	750,000	9d6+6*	14 (+5)
13	900,000	9d6+8*	12 (+7)
14	1,050,000	9d6+10*	12 (+7)

Exorcist Saving Throws					
Level	D	W	P	B	S
1	11	12	14	16	15
2	11	12	14	16	15
3	11	12	14	16	15
4	11	12	14	16	15
5	9	10	12	14	12
6	9	10	12	14	12
7	9	10	12	14	12
8	9	10	12	14	12
9	6	7	9	11	9
10	6	7	9	11	9
11	6	7	9	11	9
12	6	7	9	11	9
13	3	5	7	8	7
14	3	5	7	8	7

*Modifiers to CON no longer apply

D: Death/Poison; **W:** Wands; **P:** Paralysis/Petrify; **B:** Breath Attacks; **S:** Spells/Rods/Staves

Face

- **Requirements:** Minimum CHA 9
- **Prime requisite:** CHA
- **Hit Dice:** 1d4
- **Maximum Level:** 14
- **Armor:** Any
- **Weapons:** Any melee, Light and medium firearms
- **Languages:** Alignment, Common

The Face is the charismatic, fast-talking member of the group. The one that negotiates, barter, and charms the pants off of any would be ally or enemy. The Face is a valuable member of any group otherwise occupied by grim killers.

Combat

The Face can use most types of weapons, but prefer those that are easily concealed or are otherwise unobtrusive, as to not appear as too much of a threat.

Magic Charm

In campaigns with spell casting, or otherwise per referee's discretion, a Face gets access to a certain number of arcane or illusionist (OSE Advanced) spells. The amount is determined by their experience level.

First Impression

When running into potentially hostile creatures, the Face may add their Charisma modifier as a bonus to a referee's Reaction Rolls if they are the one to speak during an attempted parley. They may also add this bonus to retainer negotiation rolls.

The Quick and The Dead

If a parley goes south and the creatures spoken to turn hostile, the Face may attempt to quick-draw any melee weapon

and any light firearm to attack a single creature of their choice. The Face rolls a 1d6, and has a 4-in-6 chance to successfully draw and attack before anyone may react. If the subsequent attack is successful, the referee may roll for Morale with a +1 bonus if the creature was injured, and a +2 bonus if the creature was outright killed.

If the remaining creatures do not flee, combat may proceed as normal afterwards.

Barter

When bartering for goods, the Face may roll a 2d6 + Charisma modifier. Depending on the result, they may get a discount on the goods purchased. However, there is a risk of their attempts annoying the vendor, increasing cost instead. This roll may be attempted multiple times, though repeated failures carries the risk of shutting down the vendor entirely.

Barter Table	
2d6	Result
3 or less	+15% cost
4 - 6	+10% cost
7 - 8	No discount
9 - 11	5% discount
12 or more	10% discount

Charmer

At 6th level, the Face gains a +1 bonus to Charisma. They may also, once per session, reroll a failed roll associated with one of their abilities, such as First Impression or Barter.

After Reaching 9th Level

The Face may establish a business of their own, suited to their outgoing personality. This could be a night club, a brothel, a casino, or any other establishment involving socializing. This establishment will provide both a high, steady income, as well as opportunities to entertain and mingle with valuable members of the local society.



Face Arcane/Illusionist Spells						
Level	1	2	3	4	5	6
1	1	-	-	-	-	-
2	2	-	-	-	-	-
3	2	1	-	-	-	-
4	2	2	-	-	-	-
5	2	2	1	-	-	-
6	2	2	2	-	-	-
7	3	2	2	1	-	-
8	3	3	2	2	-	-
9	3	3	3	2	1	-
10	3	3	3	3	2	-
11	4	3	3	3	2	1
12	4	4	3	3	3	2
13	4	4	4	3	3	3
14	4	4	4	4	3	3

Face Level Progression			
Level	XP	HD	THAC0
1	0	1d4	19 (0)
2	1,500	2d4	19 (0)
3	3,000	3d4	19 (0)
4	6,000	4d4	19 (0)
5	12,000	5d4	17 (+2)
6	25,000	6d4	17 (+2)
7	50,000	7d4	17 (+2)
8	100,000	8d4	17 (+2)
9	200,000	9d4	14 (+5)
10	300,000	9d4+1*	14 (+5)
11	400,000	9d4+2*	14 (+5)
12	500,000	9d4+3*	14 (+5)
13	600,000	9d4+4*	12 (+7)
14	700,000	9d4+5*	12 (+7)

Face Saving Throws					
Level	D	W	P	B	S
1	13	14	13	16	15
2	13	14	13	16	15
3	13	14	13	16	15
4	13	14	13	16	15
5	13	14	13	16	15
6	11	12	11	14	12
7	11	12	11	14	12
8	11	12	11	14	12
9	11	12	11	14	12
10	11	12	11	14	12
11	8	9	8	11	8
12	8	9	8	11	8
13	8	9	8	11	8
14	8	9	8	11	8

*Modifiers to CON no longer apply

D: Death/Poison; **W:** Wands; **P:** Paralysis/Petrify; **B:** Breath Attacks; **S:** Spells/Rods/Staves



3. Racial Traits

Rather than adding whole cloth modern demihuman classes, this chapter aims to provide some additional traits to can be applied to the demihuman classes from core OSE, as well as to the demihuman race options from the Advanced edition of the game.

These new traits provide some modern flavor to each demihuman without reinventing the wheel. They are meant to be added to each race alongside their existing traits. Each race is meant to include their various sub-races that may be available as well.



Dwarf

Dwarves tend to remain very traditional even in the modern age. Long lived and stubborn, they epitomize the phrase 'If it ain't broke, don't fix it.'

Dwarves gain the following additional traits.

- **Weapons:** Any firearm. Prefer older models.

- **Old School:** When using any Revolver, a Sawed-Off Shotgun, Shotgun, Lever-Action Rifle, Service Rifle, Big Game Rifle, or any other firearm deemed sufficiently old fashioned (referee's discretion) a Dwarf gains a +1 to damage. This may further improve by +1 every 4 levels.
- **Blast Resistant:** Due to their low center of gravity and experience with mining demolitions, Dwarves have a +1 to Death saving throws to avoid the effects of explosives.

Elf

Incredibly long lived, Elves tend to remain aloof from the modern world, retreating back to the privacy of their own enclaves once they have sowed their wild oats and perhaps have made their riches in their youth.

Elves gain the following additional traits.

- **Weapons:** Any firearm. Prefer single shot firearms.
- **Elven Marksmanship:** When firing a single shot firearm, Elves suffer no penalty when firing at long range. Additionally, Elves only suffer a -2 penalty when firing weapons with the Sniper quality beyond long range.
- **Old Money:** Elves roll double their starting wealth at character creation.

Gnome

With the advent of industry, Gnomes vastly expanded on their natural inclination towards tinkering and invention. They are masters of technology, always remaining on the cutting edge, if not responsible for much of it.

Gnomes gain the following additional traits.

- **Weapons:** Light and medium firearms, appropriate to their stature.
- **Tech Adept:** Gnomes start with a 1st level Technomancy spell of their choice.
- **Jerry-Built:** Gnomes may attempt to build makeshift versions of firearms, equipment and even vehicles in the field. When given access to the right source of materials, such as a junkyard, Gnomes have a percentage chance to build a successful copy of a piece of equipment they have already once seen, at the cost of only half the normal GP price of the actual item. The exact chance of success is up to the referee's discretion, based on the complexity of the item. This process takes at least several hours even for simple items, and may only be performed once per experience level. Multiple Gnomes may work together to improve their chances.

Halfling

Even in modern times, Halflings prefer a simple, comfortable living, preferably in rural areas away from the bustle of big cities. Halflings that pursue careers involving danger and gunplay are usually seeking to fund an easy life for their extended family, at their own expense.

Halflings gain the following additional traits.

- **Weapons:** Light and medium firearms, appropriate to their stature.
- **The Bigger They Are:** When targeted by larger opponent, Halflings may forgo their normal Defensive Bonus of +2 AC in exchange for a +2 bonus to damage against the same creature when the Halfling makes their next attack. This improves to +4 damage at 6th level.
- **Good Fortune:** Halflings are often quite lucky, despite their general adversity to danger. Once per session they may reroll any failed roll of their choice.

Half-Orc

Often still keeping in touch with their Orcish roots, many young Half-Ocs choose potentially violent professions such as joining the military, law enforcement, or even indulging in a life of crime.

Half-Orcs gain the following additional traits.

- **Weapons:** Any firearm. Prefer automatic weapons.
- **Spray and Pray:** When using Auto Fire attacks, Half-Orcs gain a +1 bonus to hit and increase the attack's damage by one extra die step. For example, d8 becomes d10. Weapons that are already d12 gain a +2 bonus instead.
- **Take The Pain:** Once per session Half-Orcs may attempt to shrug off any single die of damage by rolling an equal die and reducing the damage by their own amount rolled.

Human

Humans gain a +5% bonus to XP in campaigns with other races.



4. Weapons

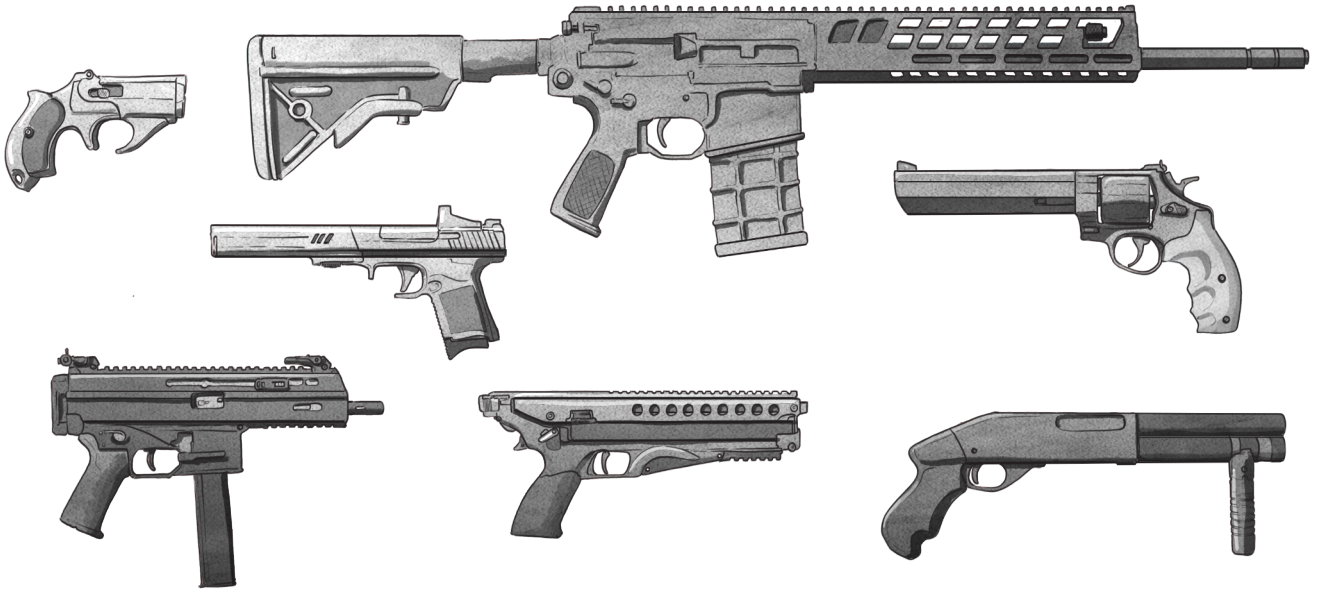

Weapons in Modern Necessities come in multiple shapes and sizes, especially the firearms. However, rather than individual, named real world firearm models, they have been designed around generic weapon types instead. For roleplaying purposes it is up to individual players or the referee to have a character find and carry specific models within the actual campaign world, should they wish to do so.

Firearm Categories

Firearms in Advanced Modernity come in 3 different categories, as follows.

Light: Light firearms are those easily held in one hand, either due to compact size or light weight, like pistols.

Medium: Medium firearms are bigger, though still relatively compact weapons, like sub machine guns, shotguns and assault rifles.

Heavy: Heavy firearms are large and cumbersome for the average person to carry. This includes machine guns, rocket launchers and anti-materiel rifles and the like.

Firearm Qualities

While in general firearms work in the same manner as any other weapon in official materials, the following custom qualities apply as well.

Auto Fire: Some firearms are equipped with the ability to fire fully automatic. Many of these target an area, requiring you to hit a certain Armor Class number for the rounds to land on target. A miss simply means the rounds went wild or impacted cover.

Auto Fire can be used in four different ways. These are as following.

- **Burst:** You target a single creature with a -1 penalty to hit and your range limited to medium. If successful, you increase the weapon's normal damage by one die step for each damage die. For example, d6 becomes d8. Weapons that are d12 get a +2 damage bonus instead.
- **Full-Auto:** You target a AC 5 (14) point within your weapon's short range with a -2 penalty to hit (replacing the normal +1 bonus), firing in a 10 foot radius sphere. Creatures caught in the attack take

your weapon's normal damage, with a successful **save vs. Death** indicating half damage.

- **Suppressive:** You target a AC 6 (13) point within your weapon's short range with a -2 penalty to hit (replacing the normal +1 bonus), firing in a 15 foot radius sphere. Creatures caught in the attack lose half their encounter movement rate until the next turn, with a successful **save vs. Paralysis** indicating they avoided being suppressed.
- **Spray:** You fire out in a 15 foot wide cone out to half your weapon's short range, and with a -4 penalty to hit (replacing the normal +1). Creatures caught in the attack take your weapon's Burst damage, with a successful **save vs. Death** indicating half damage. You must always reload after using Spray.

Blast: Blast weapons are those that detonate their payload with explosive effect, such as grenade launchers. With a blast weapon, you target a AC 5 (14) point within your weapon's range, detonating within a sphere of a radius indicated with the individual weapon. Creatures caught in the attack take your weapon's normal damage, with a successful **save vs. Death** indicating half damage.

Covert: Covert weapons are small enough to be hidden somewhere on the body and pass notice. They generally only have a 1-in-6 chance to be found during a casual pat down. A more thorough search by a professional will likely raise the chance the weapon is found.

Sniper: Firearms with the Sniper quality can be aimed for additional accuracy, usually due to being outfitted with telescopic sights, or just because they are so powerful. Should you so wish, you can spend your round carefully aiming a Sniper weapon, gaining a +2 to hit on your next round while firing within the weapon's listed ranges, stacking with any other bonus you may get.

Alternatively, you can attempt to shoot beyond long range at a -4 penalty instead, up to twice the weapon's max range but

at half the damage. For example, a Sniper firearm with a max range of 750 feet can be fired up to 1500 feet with the -4 penalty when aimed the previous turn.

You must re-aim your firearm before every long range shot like this. A referee may decide that being successfully hit that round while a character is aiming disrupts the aiming process.

Spread: Firearms with this quality have a 2-in-6 chance of hitting another creature for half damage up to the firearm's medium range, as long as they are within 5 feet of the original target. This can happen even if the attack on the original target is missed. Switching ammo types may remove this quality.

Reloading Firearms

Reloading a firearm in Modern Necessities is a fairly simple mechanic, and is suitable for a more cinematic feel. Sometimes your gun just doesn't seem to run out of bullets!

Instead of carefully tracking how many rounds you may have in a magazine or ammo belt, the referee will simply make you roll to see if you must reload after an encounter, or at any point of their choice during the encounter, if the weapon used was capable of multiple shots or the encounter has gone on for any extended period.

If forced to reload during an encounter, you lose the ability to attack with that weapon until the next round.

Reload rolls are done with a d6. The number in the brackets behind the Reload property in the weapon tables indicates the chance of a reload needing to happen. For example, a Pistol reloads on a roll of 2-in-6, while a Grenade Launcher reloads on a roll of 4-in-6.

Those weapons capable of Auto Fire have a second number listed, indicating the reload chance when largely using Burst, Full-Auto and Suppressive attacks. Weapons must always reload after using Spray attacks.





Melee					
Weapon	Damage	Range	Cost (gp)	Weight (in coins)	Qualities
Knuckle Duster	1d2+1	-	2	1	Blunt, Melee, Covert
Straight Razor	1d3	-	2	1	Melee, Covert
Combat Knife	1d4	10/20/30	5	2	Melee, Missile
Throwing Knife	1d4+1	20/30/40	5	1	Missile
Bayonet	1d4+1	-	10	5	Melee, *Charge
Baseball Bat	1d6	-	20	4	Blunt, Melee
Nunchucks	1d6+1	-	50	2	Blunt, Melee
Machete	1d6	-	25	3	Melee
Sledge Hammer	1d8	-	100	30	Blunt, Melee, Slow, Two-Handed
Fire Axe	1d8+1	-	110	20	Melee, Slow, Two-Handed
Stun Baton	*1d4	-	50	5	Blunt, Melee
Chainsaw	2d6	-	80	100	Melee, Slow, Two-Handed
Kama	1d6+1	10/20/30	100	5	Melee, Missile
Ninjato	1d8	-	200	3	Melee
Katana	1d10+1	-	500	8	Melee
Cane Sword	1d10	-	400	5	Melee, Covert

*Has special properties/modifiers. See description.

Melee Weapons

The following modern themed melee weapons are available in Modern Necessities.

Knuckle Dusters

AKA Brass Knuckles. This time tested weapon, popular with thugs, fits over the hand to do increased unarmed damage.

Straight Razor

While designed for shaving, a straight razor kept in one's boot is a decent weapon in a pinch.

Combat Knife

Your average fighting and survival knife. Stand issue for military personnel. Can be thrown.

Throwing Knife

A knife balanced for throwing. May also represent Shurikens and the like.

Bayonet

This dagger-like weapon fits on the end of a rifle, allowing soldiers to stab enemies in a pinch. Counts as a Combat Knife when not mounted on a rifle. Can also be used for special charge attacks when mounted. Moving at least 20 feet in a round doubles damage done.



Baseball Bat

Your every day Louisville Slugger. Perfect for breaking knees.

Nunchucks

Two sticks with a piece of rope or chain between them, nunchucks are the weapon of choice of Kung Fu experts and fans of mutated turtles alike.

Machete

A large, broad blade used for clearing jungle. Great for clearing out limbs as well.

Sledge Hammer

A large, heavy construction hammer. Bashes skulls as well as it bashes walls.

Fire Axe

Carried by firefighters and often stored away in buildings for use in emergencies. Sometimes slamming it into someone's chest counts as an emergency.

Stun Baton

A variant of the cattle prod, a stun baton is great for dealing with unruly individuals. A Stun Baton can not kill and only causes subdual damage. Per referee's discretion, a successful hit imposes a **save vs Paralysis**. Failure means the creature hit is paralysed for one round.

Chainsaw

Great for cutting down trees, as well as your enemies. Chainsaws are powerful but very loud. Per referee's discretion, a chainsaw must be routinely refueled.

Kama

A sharp one-handed sickle with a chain attached. Can be thrown and pulled back by trained users.



Ninjato

Shorter Katana-like weapons popularly used by (mall) Ninjas.

Katana

A classic weapon, popular with true professionals. A Katana allows one to kill in style.

Cane Sword

A slightly lighter, straight bladed variant of the Katana, hidden within an inconspicuous looking cane. The weapon of choice of blind assassins.

Light Firearms

Weapon	Damage	Range	Cost (gp)	Weight (in coins)	Qualities
Stun Gun	1d4	10/20/30	15	5	Missile, Reload (6), Covert
Pocket Pistol	1d4	30/60/90	30	10	Missile, Reload (2), Covert
Pocket Revolver	1d4+1	30/60/90	40	15	Missile, Reload (3), Covert
Pistol	1d6	40/80/120	60	20	Missile, Reload (2)
Magnum Pistol	1d8	60/120/180	100	40	Missile, Reload (3)
Revolver	1d6+1	40/80/120	70	25	Missile, Reload (3)
Magnum Revolver	1d8+1	60/120/180	110	50	Missile, Reload (4)
Sawed-Off Shotgun	1d10	20/40/60	60	60	Missile, Reload (5), Spread
Machine Pistol	1d6	40/80/120	200	30	Missile, Reload (2/4), Auto Fire

Light Firearms

Stun Gun

A stun gun fires two electrified prongs attached by wires into the target, stunning them with powerful electrical shocks. Only causes subdual damage. A **save vs. Paralysis** resists, per referee's discretion.

Pocket Pistol

A small, light-weight automatic pistol easily shoved in a pocket or hidden up one's sleeve.

Uses **Pistol Ammo**. A pocket pistol usually comes in calibers like .32 ACP and 9mm Short.

Pocket Revolver

The revolver version of the pocket gun, generally considered more reliable.

Uses **Revolver Ammo**. A pocket revolver usually comes in calibers like .22 Long Rifle and .32 Colt.

Pistol

Your standard semi-automatic pistol, such as the Beretta 92FS or venerable Colt M1911A1. Used by military, police and civilians the world over.

Uses **Pistol Ammo**. A pistol usually comes in calibers like 9mm Para and .45 ACP.

Magnum Pistol

This heavier, more powerful variant of semi-automatic pistol was originally designed for hunting and target shooting. However, models like the Desert Eagle have since become quite popular for general purposes as well.

Uses **Magnum Ammo**. A magnum pistol usually comes in calibers like .50 Action Express and .475 Wildey.

Revolver

A true classic. The revolver, aka sixgun, goes all the way back to the time of the old west, but remains popular to this day.

Uses **Revolver Ammo**. A revolver usually comes in calibers like .38 Special and .44



Special.

Magnum Revolver

The big brother to the normal revolver, perfect for stopping anyone in their tracks. Magnum variants like the Smith & Wesson model 29 were made quite popular by hard boiled cop movies.

Uses **Magnum Ammo**. A magnum revolver usually comes in calibers like .44 Magnum and .454 Casull.

Sawed-Off Shotgun

A standard double barrel shotgun (over/under or side by side) sawed-off to handcannon proportions. Popular with road bandits.

Uses **Shotgun Ammo**. A sawed-off shotgun usually comes in calibers like 16 Gauge and 12 Gauge.

Machine Pistol

Essentially small sub machine guns, machine pistols are usually full-auto variants of normal semi-automatic pistols, like the Glock 18, or other compact, one-handed spray and pray weapons like the Uzi.

Uses **Pistol Ammo**. A machine pistol usually comes in calibers like 9mm Makarov and 9mm Para.



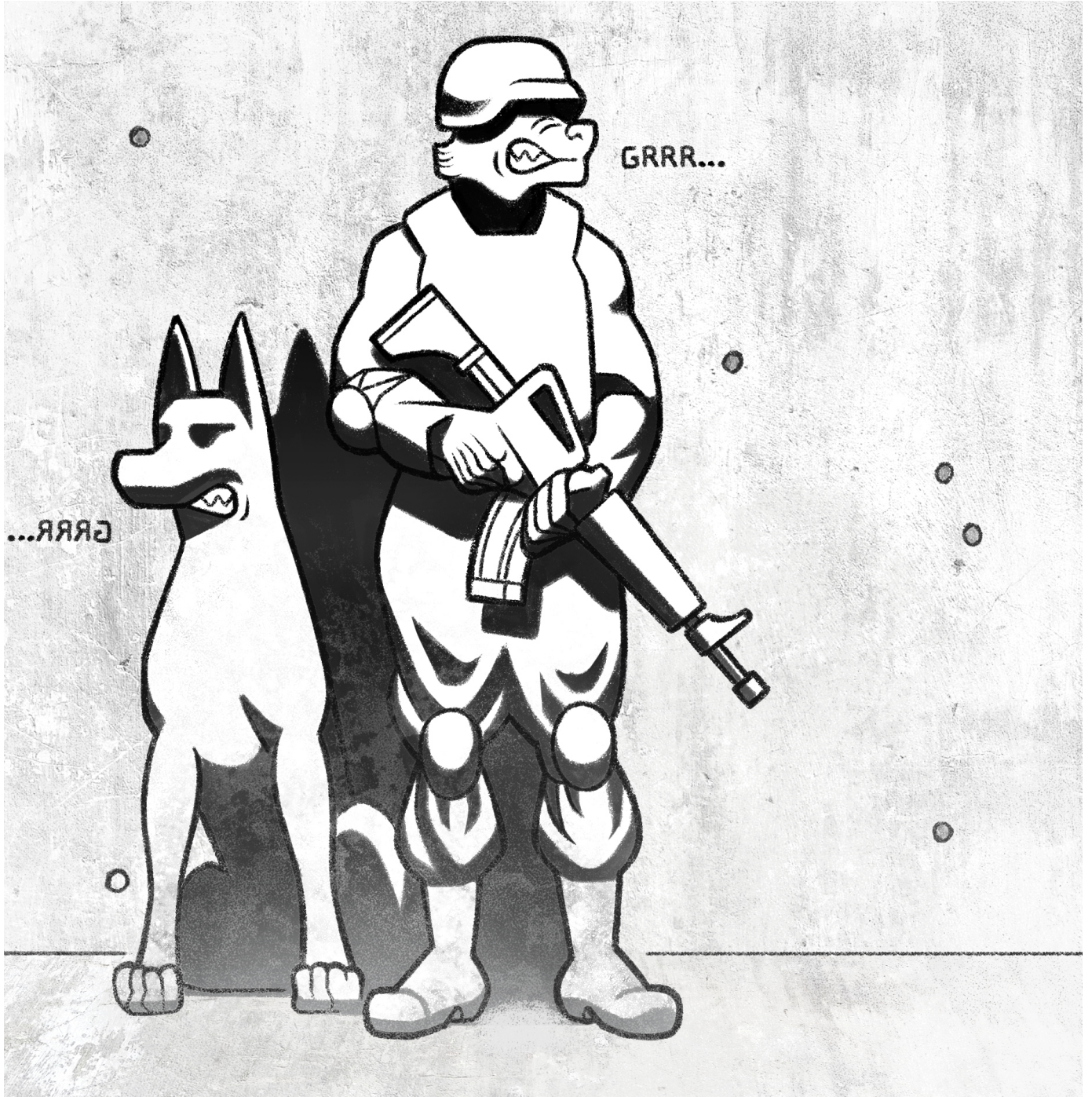

Medium Firearms					
Weapon	Damage	Range	Cost (gp)	Weight (in coins)	Qualities
Shotgun	2d6	30/60/90	90	70	Missile, Reload (3), Spread, Two-Handed
Lever Action Rifle	1d6	100/200/300	100	60	Missile, Reload (3), Two-Handed
Service Rifle	1d10	180/360/540	150	120	Missile, Reload (4), Two-Handed
Hunting Rifle	1d8+1	200/400/600	200	70	Missile, Reload (3), Sniper, Two-Handed
Carbine	1d6+1	80/160/240	300	50	Missile, Reload (2), Two-Handed
Sporting Rifle	1d8	100/200/300	400	60	Missile, Reload (2), Two-Handed
Big Game Rifle	2d8	120/240/360	700	150	Missile, Reload (5), Two-Handed
Sub Machine Gun	1d6	40/80/120	600	50	Missile, Reload (2/4), Auto Fire, Two-Handed
Assault Rifle	1d8	100/200/300	700	60	Missile, Reload (2/4), Auto Fire, Two-Handed
Battle Rifle	1d10	150/300/450	800	90	Missile, Reload (3/5), Auto Fire, Two-Handed
Combat Shotgun	2d6	30/60/90	600	80	Missile, Reload (3/5), Auto Fire, Spread, Two-Handed
Marksman Rifle	1d8	200/400/600	900	90	Missile, Reload (2), Sniper, Two-Handed
Sniper Rifle	1d10+1	250/500/750	1,000	100	Missile, Reload (3), Sniper, Two-Handed
Light Machine Gun	1d8	100/200/300	1,000	150	Missile, Reload (1/3), Auto Fire, Two-Handed
Medium Machine Gun	1d10	200/400/600	1,500	250	Missile, Reload (2/4), Auto Fire, Two-Handed, Slow
Grenade Launcher	4d6	60/120/180	1,600	120	Missile, Reload (4), Blast (20'), Two-Handed

Medium Firearms

Shotgun

Your average pump-action or semi-automatic shotgun, such as the Remington 870 and Benelli M1. Shotguns are popular for hunting, self-defense and law enforcement use.

Uses **Shotgun Ammo**. A shotgun usually comes in calibers like 12 Gauge and 10 Gauge.

Lever Action Rifle

A legend of the old west, such as the Winchester 1873, lever guns are still used for hunting and for cowboy shooting competitions.

Uses **Magnum Ammo** or **Rifle Ammo**. A lever-action usually comes in calibers like .45 Long Colt and .30-30 Winchester.

Service Rifle

Still found in various hot spots, as well as up in grandpa's attic, what World War 1 and 2 era service rifles such as the M1 Garand and Mosin Nagant lack in modern flair they makes up for in power.

Uses **Rifle Ammo**. A service rifle usually comes in calibers like .30-06 Springfield and 7.62x54R.

Hunting Rifle

These scoped rifles can be found in just about any sporting goods store, or hanging from a cabin's wall. Whether it's to hunt for sport, or to put food on the table, hunting rifles like the Remington 700 do the job quite well.

Uses **Rifle Ammo**. A hunting rifle usually comes in calibers like .270 Winchester and .308 Winchester.

Carbine

Carbines are usually compact, semi-automatic weapons, such as the classic M1 Carbine or modern, shortened AR-15 variants.

Uses **Assault Rifle Ammo**. A carbine usually comes in calibers like .30-M1 and

.223 Winchester.

Sporting Rifle

A sporting rifle is essentially just a full-size AR-15, or other similar weapons like the Mini-14 and civilian versions of the AK.

Uses **Assault Rifle Ammo**. A sporting rifle usually comes in calibers like .223 Winchester and 7.62x39mm.

Big Game Rifle

These especially large and powerful hunting rifles were designed to take down the most dangerous game animals, such as great cats and pachyderms.

Uses **Heavy Rifle Ammo**. A big game rifle usually comes in calibers like .375 Holland & Holland and .500 Nitro Express.

Sub Machine Gun

Originally designed for clearing trenches, such as with the classic Thompson M1928 'Tommy Gun', more modern variants like the H&K MP5 continue to be a great choice for close quarters battle.

Uses **Pistol Ammo**. A sub-machine gun usually comes in calibers like 9mm Para and .45 ACP.

Assault Rifle

The main weapon of any modern military or group of freedom fighters, assault rifles that fire so called intermediate calibers, like the M16 and AK-74 can be found all over the world.

Uses **Assault Rifle Ammo**. An assault rifle usually comes in calibers like 5.56mm NATO and 7.62x39mm.

Battle Rifle

The bigger, slightly outdated brother to the assault rifle, such as the FN FAL and H&K G3. Battle rifles fire more powerful rounds, which also makes the weapons heavier.

Uses **Rifle Ammo**. A battle rifle usually comes in calibers like 7.62mm NATO.



Combat Shotgun

Full-auto combat shotguns like the Atchisson AA-12 and Saiga 12 are the perfect room clearers, only leaving destruction in their wake.

Uses **Shotgun Ammo**. A combat shotgun usually comes in calibers like 16 Gauge and 12 Gauge.

Marksman Rifle

Designed to extend an infantry squad's range, a marksman rifle is usually a standard issue assault rifle, rebuilt for accuracy, equipped with optics, and limited to semi-automatic fire.

Uses **Assault Rifle Ammo**. A marksman rifle usually comes in calibers like 5.56mm NATO.

Sniper Rifle

Full size sniper rifles, such as the USMC M40 and the H&K PSG-1, were designed to reach out and touch someone across extended ranges. These rifles are often purpose built just for sheer accuracy, equipped with match barrels and powerful optics.

Uses **Rifle Ammo**. A sniper rifle usually comes in calibers like 7.62mm NATO and .300 Winchester.

Light Machine Gun

The average light machine gun carried by the modern soldier, such as the M249 SAW or Russian RPK, fires the same intermediate ammo as standard assault rifles, but are instead fed from extended ammo belts that allow for a large volume of fire.

Uses **Assault Rifle Ammo**. A light machine gun usually comes in calibers like 5.56mm NATO and 7.62x39mm.

Medium Machine Gun

The larger, heavier brother to the so called 'Squad Automatic Weapon', these machine guns, like the M60 and Russian PKM, fire more powerful calibers, and are often used in fixed positions such as mounted upon vehicles.

Uses **Rifle Ammo**. A medium machine gun usually comes in calibers like 7.62mm NATO and 7.62x54R.

Grenade Launcher

Modern grenade launchers are often of the rotary type, like the Milkor MGL. These are essentially large revolvers that fire 40mm explosive rounds in quick succession to rain destruction upon anything in their way.

Uses **40mm Grenade Launcher Ammo**.



Heavy Firearms

Weapon	Damage	Range	Cost (gp)	Weight (in coins)	Qualities
Anti-Materiel Rifle	3d6	500/1000/1500	2,000	300	Missile, Reload (3), Sniper, Two-Handed, Slow
Heavy Machine Gun	3d6	300/600/900	2,500	250	Missile, Reload (1/3), Auto Fire, Two-Handed, Slow
Flamethrower	4d6	20/40/60	3,500	500	*Missile, Reload (5), Two-Handed, Splash weapon, Slow
Rocket Launcher	5d6	300/600/900	2,000	150	Missile, Reload (6), Blast (20'), Two-Handed, Slow

*See weapon description.

Heavy Firearms

Anti-Materiel Rifle

As the name suggests, these rifles were designed to take out equipment, such as parked airplanes or even munitions, at range. This is often a more cost effective method than using explosives and the like. However, they were soon found to be quite effective at taking out living targets at incredible long ranges as well.

Uses **Heavy Rifle Ammo**. An anti-materiel rifle usually comes in calibers like .338 Lapua and .50 BMG.

Heavy Machine Gun

These large machine guns, like the Browning M2, are usually mounted on vehicles. A character with at least 17 Strength may carry one with a -50% penalty to encounter movement rate.

Uses **Heavy Rifle Ammo**. A heavy machine gun usually comes in calibers like .50BMG and 14.5mm.

Flamethrower

A terrifying weapon first perfected during World War 1, flamethrowers shoot a stream of flaming napalm at extended ranges, setting fire to everything it touches.

Flamethrowers shoot out in a 10 foot wide cone. Creatures in its path must **save vs Breath Attacks -2** or take the listed Splash weapon damage.

Uses **Flamethrower Ammo**.

Rocket Launcher

These weapons fire either rocket propelled grenades, or recoilless rifle rounds, designed to take out vehicles, bunkers and clusters of personnel. Variants like the RPG-7 are in wide spread use in hot spots around the world.

Per referee's discretion, a Rocket Launcher round may be able to track a vehicle or sufficiently large creature by heat seeking or radar technology, such as in the case of Stinger missile launchers.

Uses **Rocket Launcher Ammo**.



Explosives

Weapon	Damage	Range	Cost (gp)	Weight (in coins)	Qualities
Molotov Cocktail	2d6	20/30/40	10	10	Missile, Splash
Pipe Bomb	3d4	20/30/40	30	10	Missile, Blast (10')
Frag Grenade	3d6	20/30/40	50	5	Missile, Blast (15')
Stun Grenade	3d6	20/30/40	50	5	Missile, Blast (15')
Flash Grenade	-	20/30/40	60	5	Missile, Blast (20')
Tear Gas Grenade	-	20/30/40	75	5	Missile, Blast (30')
Smoke Grenade	-	20/30/40	25	5	Missile, Blast (30')
Plastic Explosives	4d8	10/20/30	250	20	Missile, Blast (25')
Dynamite	4d6	20/30/40	150	5	Missile, Blast (15')
Landmine	4d6	-	300	30	Blast (20')
Anti-Vehicle Mine	4d10	-	500	50	Blast (30')

Explosives

The following explosives are available for use in Modern Necessities.

Molotov Cocktail

A glass container filled with gasoline or some other flammable liquid, stuffed with an oily rag. Can be lit and thrown. A **save vs. Breath Attacks** can extinguish the flames covering a creature.

Pipe Bomb

A homemade explosive consisting out of a metal pipe filled with black powder and nails. Can be thrown or set off with detonators.

Frag Grenade

A standard military issue fragmentation grenade, quite commonly carried and deployed by professional soldiers and mercenaries.

Stun Grenade

A standard stun grenade, often used by SWAT units for non-lethal take downs. Causes subdual damage.

Flash Grenade

A flash grenade explodes in a bright loud and a loud bang. Used by SWAT units and the like to disorient opponents before engaging. Creatures caught in its radius must make a **save vs. Paralysis** or be blinded and deafened.

Tear Gas Grenade

This grenade unleashed a noxious cloud of tear gas, making it perfect for crowd control. Creatures caught in its radius must make a **save vs. Paralysis** every turn or be unable to move and attack. The gas cloud lasts for 1 turn.

The gas flow can be dispersed by sufficient wind. Because the gas is denser than air, it sinks to the lowest point, flowing down hills, into holes, and so forth.



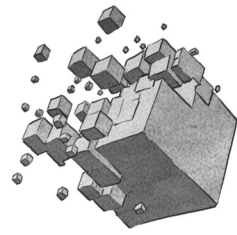
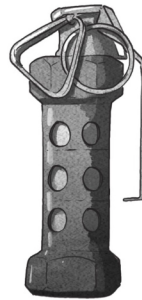
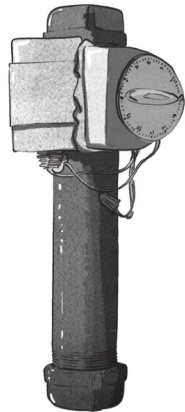

Smoke Grenade

This grenade unleashed a thick cloud of colored smoke. It can be used to conceal one's position while moving, or for signaling purposes, such as marking landing sites and artillery strikes. The smoke cloud lasts for 1 turn.

Creatures inside the smoke can only see out to a maximum of 5 feet. The smoke can be dispersed by sufficient wind.

Plastic Explosives

These malleable explosives like C4 or Semtex are used for various military, criminal and industrial purposes, and are the first choice for any serious demolition work. Plastic Explosives require detonators to work.

Plastic Explosives come in bricks weighing 20 coins. Characters may combine bricks to increase explosive yield. Each additional brick adds 1d8 damage and 5 feet of radius, up to a maximum of 10d8 damage and a 40 foot radius.

Dynamite

One of the most common and famous types of explosives, used for mining and construction purposes for over a century. Simply light the fuse and throw, or attach a suitable detonator.

Dynamite comes in red paper sticks weighing 5 coins. Characters may

combine sticks to increase explosive yield. Each additional brick adds 1d6 damage and 5 feet of radius, up to a maximum of 10d6 damage and a 30 foot radius.

Landmine

Landmines come in a few shapes and sizes, such as Bouncing Betties and Claymore mines. In either case, they are a quite deadly threat common to many war zones.

A landmine will detonate when a creature of sufficient weight steps on it, or otherwise triggers it, such as with a tripwire. When searching for mines creatures only have a 5% chance to spot them visually.

Anti-Vehicle Mine

These oversize landmines are designed to destroy and cripple vehicles.

An anti-vehicle mine will detonate when a vehicle of sufficient weight drives over it, or otherwise triggers it, such as with a motion sensor. When searching for anti-vehicle mines creatures only have a 10% chance to spot them visually.

Firearm Attachments

Attachment	Cost (gp)	Weight (In coins)
Bayonet	10	5
Bipod	500	1
Extended Magazine	1,000	10
Foregrip	150	5
Laser Aiming Module	500	2
Night Vision Scope	1,500	20
Red Dot Sight	500	5
Scope	1,000	10
Shotgun Choke	400	2
Suppressor	500	5
Tac Light	50	5
Underbarrel Shotgun	1,000	50
Underbarrel Grenade Launcher	1,500	80

Firearm Attachments

Modern Necessities has multiple attachments and modifications you can apply to your firearms, from suppressors to night vision scopes.

All of these attachments can be swapped out on the fly. It takes a single round to either attach or remove an attachment.

Per referee's discretion, you can only have one of certain attachments. If you already have a Red Dot Sight installed, you might not also have a Scope for instance. Likewise, you can generally have only one underbarrel attachment in a more realistic setting.

Bayonet

A bayonet is simply a knife or dagger you attach to the end of your two-handed weapon. Allows the weapon to do 1d4+1 melee damage, and gives the special Charge melee attack.

Bipod

When properly braced against the ground or other solid surface, a bipod removes the to hit penalty of every Auto Fire

attack except when using Spray on a two-handed weapon. The penalty to Spray is reduced by half (to -2) instead.

Extended Magazine

An extended magazine reduces the chance a weapon must reload by 1. For example 3-in-6 becomes 2-in-6.

Foregrip

A foregrip reduces the to hit penalty of every Auto Fire attack by -1. This does not stack with the reduced penalties from bipods.

Laser Aiming Module

A Laser Aiming Module gives a weapon an additional +1 bonus to hit to a maximum range of 50 feet. However, the laser is highly visible.

Night Vision Scope

A Night Vision scope gives a character infravision out to the weapon's medium range. This only applies if they are actively looking through the scope. It also gives the weapon the Sniper quality up to medium range when used in darkness, though the character may not double his



effective range.

Red Dot Sight

A Red Dot Sight allows for more accurate aim, getting more bullets on target for a quicker kill. Adds a +1 bonus to damage.

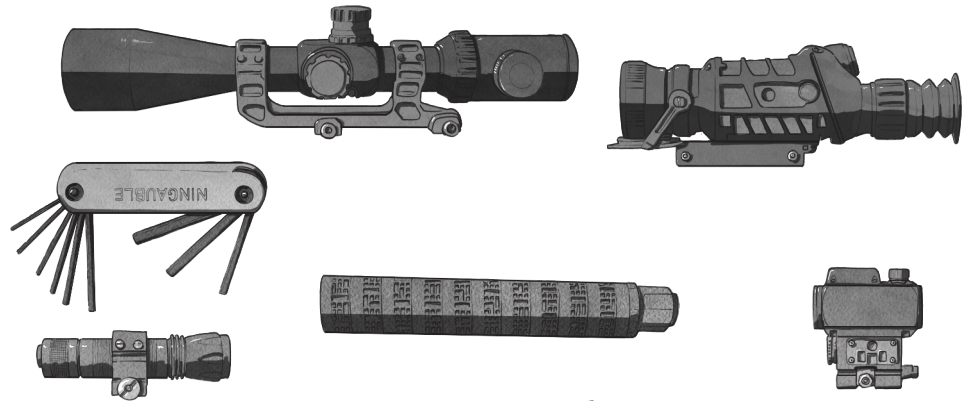

Scope

A Scope allows for more accurate aiming at long range. When attached, it gives a weapon the Sniper quality.

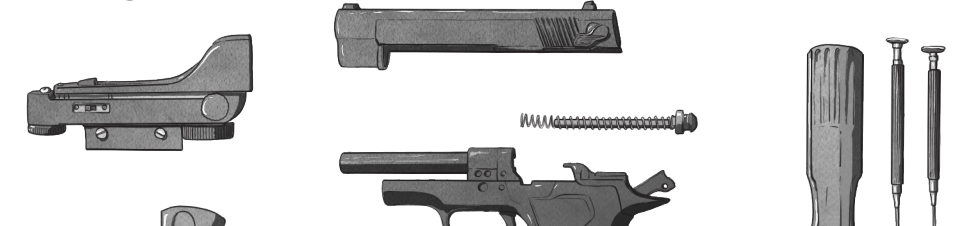

Shotgun Choke

Narrows the spread of shotgun pellets. Increases a shotgun's ranges by +25% when using standard buckshot ammo or Dragon's Breath rounds. Removes the ability to fire slugs.

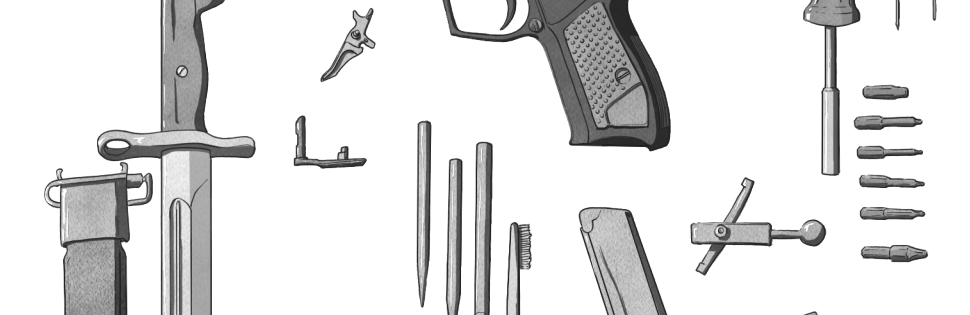

Suppressor

A suppressor increases the chance to go unnoticed when firing a weapon, such as allowing a sniper to shoot twice before their chance of discovery goes up.



Tac Light

A tac light attaches beneath the barrel of a firearm. It casts a 50 foot long, 10 foot wide beam of light that is highly visible.

Underbarrel Shotgun

Attaches a pump-action shotgun beneath your two-handed weapon. Can be switched to on the fly, taking a single round to do so. Has the same statistics as a normal shotgun.

Underbarrel Grenade Launcher

Attaches a compact, single shot grenade launcher beneath your two-handed weapon. Can be switched to on the fly, taking a single round to do so. Has the same statistics as a normal grenade launcher, except that it must be reloaded after every shot.

Ammunition

Modern Necessities has multiple types of ammunition you can apply to your firearms beyond the standard loads. All of these modify attacks in some way.

Armor Piercing

Armor piercing rounds generally feature a steel or other type of hard metal core to help them penetrate better. This however increases the chance of a round simply passing through flesh and doing 'minimum' damage. Armor piercing rounds give a +1 attack bonus at the cost of dropping damage by one die step. Example, 1d6 becomes 1d4. If a weapon is already a d4 they do a flat -1 damage instead, to a minimum of 1.

Per referee's discretion, Armor Piercing rounds may also improve the weapon's **Vehicle Damage (VD)** by +1.

Hollow Point

Hollow point rounds, as the name suggest, feature a hollow at the tip of the bullet, helping the round to expand when it hits flesh, increasing the size of the wound channel. Hollow point rounds give a -1 penalty to attacks, in exchange for increasing the damage by one die step. Example, 1d6 becomes 1d8. If a weapon is already a d12 they gain a flat +2 damage bonus instead.

Rubber

Popular with riot squads, rubber rounds are meant to cause pain rather than to kill. Rubber rounds only cause subdual damage, can only be fired out to medium range, and the overall damage of the firearm is reduced by two die steps. Example, 1d8 becomes 1d4. If a weapon is already a d4 they do a flat -2 damage instead, to a minimum of 1.

Slug

Used in shotguns, slug rounds increase the weapon's damage by one die step. Example, 1d10 becomes 1d12. If a weapon is already a d12 they gain a flat +2 damage bonus instead. However, the shotgun loses the spread quality.

Dragon's Breath

Used in shotguns, these rounds packed with magnesium pellets fire a gout of flame in a 5 foot wide cone up to the weapon's short range. Creatures in its path must **save vs Breath Attacks** or take the weapon's listed damage as Splash damage.

Silver

Silver rounds will damage certain creatures that are otherwise immune to regular attacks.

Magic Bullet

Infused with arcane energy, magic bullets will damage creatures that are otherwise immune to non-magical rounds.

Vorpal

The ultimate in ranged projectiles, vorpal bullets have the ability to go right through creature up to the firearm's medium range, hitting every other creature behind it. Any creature past the first one hit however must make a **save vs Death** to only take half damage. Vorpal rounds will equally ignore most mundane types of cover, and will damage creatures that are otherwise immune to non-magical or non-silver rounds.



Ammo Costs (Per Reload)

Ammo	Cost (gp/multiplier)	Weight (In coins)
Pistol Ammo	10	5
Revolver Ammo	10	5
Magnum Ammo	20	10
Shotgun Ammo	15	10
Rifle Ammo	25	15
Assault Rifle Ammo	30	15
Heavy Rifle Ammo	50	25
Grenade Launcher Ammo	100	50
Rocket Launcher Ammo	150	50
Flamethrower Ammo	300	200
Armor Piercing	x2	1
Hollow Point	x2	1
Rubber	Half	1
Slug	x2	1
Dragon's Breath	x3	1
Silver	x4	1
Magic Bullet	x6	1
Vorpal	x10	1

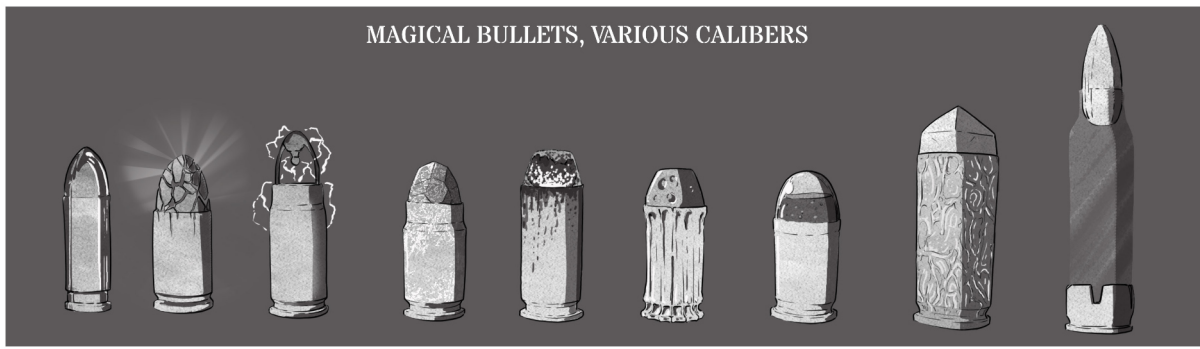

SILVER RADIANT ELECTRICITY FROST FIRE NECROTIC ACID STARMETAL VORPAL

AMMUNITION CONTAINERS



GOBLIN



ELVEN



DWARVISH



ORC

5. Armor

Armor				
Armor	AC	Cost (gp)	Weight (In coins)	Type
Undercover Vest	8 (11)	10	100	Light
Kevlar Vest	7 (12)	30	200	Light
Plate Carrier	5 (14)	100	300	Light
Flak Jacket	7 (12)	200	250	Light
Sneak Suit	9 (10)	750	50	Light
NBC Suit	7 (12)	150	300	Light
VIP Suit	5 (14)	500	50	Light
Kevlar Suit	4 (15)	300	500	Heavy
Bomb Suit	4 (15)	1,000	800	Heavy
Combat Armor	3 (16)	2,000	600	Heavy
Exo Suit	2 (17)	5,000	800	Heavy
Riot Shield	+1 bonus	50	100	Light
Ballistic Shield	Acts as Partial Cover	300	400	Light

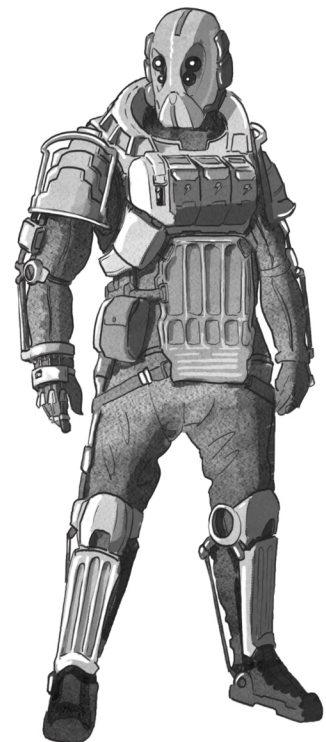

Armor

There are multiple types of armor available in Modern Necessities. Some of these have additional special qualities as detailed in their individual descriptions.

Undercover Vest

Also called a stab proof vest, this light weight armor can be worn under clothing and only has a 1-in-6 chance to be noticed during a casual search. Against edged weapons the undercover vest has a +1 bonus to AC.

Kevlar Vest

A standard kevlar vest, as worn by law enforcement and body guards and the like. Can be worn under clothing, though will be obvious during a search.

Plate Carrier

Common with military troops, the Plate Carrier combines body armor with the ability to carry extra equipment within its many pouches. Increases carry capacity by 400 coins.

Flak Jacket

A variant of the kevlar vest, the flak jacket offers additional protection against explosives. Characters wearing a flak jacket gain a +2 bonus to **save vs. Death** rolls against Blast weapons.

Sneak Suit

This light weight, black rubberized body suit was designed for stealth missions. It can be worn under clothing, but will only be effective once said clothing has been discarded. A character that has either the **Move Silently** or **Hide In Shadows** skills will gain a +10% bonus when wearing a sneak suit. A character without either skill will gain them at an effectiveness equal to half their level as a Thief, rounded down, when wearing a sneak suit.

NBC Suit

NBC Suits (Nuclear, Biological, Chemical) protect against hazardous environments, such as during outbreaks

of disease or toxic spills. While wearing the suit the character is immune to these effects. A character can only wear a NBC suit for up to 12 hours before they must remove it and rest. Per referee's discretion, a NBC suit may be damaged from combat or other hazards, negating its effectiveness.

VIP Suit

Looking like a stylish business suit or tuxedo, a VIP suit is instead made out of high-end and light weight kevlar or even spidersilk weaves. Bullet proof, stylish and discreet all in one.

Kevlar Suit

Popular with SWAT teams and career criminals alike, the Kevlar Suit provides full body protection against small arms. It comes complete with sinister hockey-like ballistic mask.

Bomb Suit

Worn by EOD specialists, the bomb suit is the pinnacle of personal protection against explosives. Characters wearing a bomb suit gain a +6 bonus to **save vs. Death** rolls against Blast weapons. However, characters also have their encounter movement rate reduced by -50%.

Combat Armor

The latest in military body armor, Combat Armor is made out of advanced kevlar blends and high-impact polymers and ceramics. The full face helmet has built in **Night Vision Goggles** and **Gasmask**. The chest area features numerous built in pouches, increasing carry capacity by 600 coins.

Exo Suit

An evolution of the Combat Armor concept, currently being tested in various military R&D labs. The Exo Suit combines improved Combat Armor with an servo-assisted exo skeleton, improving the wearer's speed and power. The suit protects against hazardous environmental effects, and the full face helmet has built in **Thermal Goggles** and **Gasmask**. The chest area features

numerous built in pouches, which combined with the user's boosted strength increases carry capacity by 1200 coins.

While wearing an Exo Suit, a character has **18 Strength** and **+25% encounter movement rate**.

Riot Shield

A sturdy shield made out of clear polymer, made for use during riot control.

Ballistic Shield

A heavy shield made out of thick kevlar, designed to serve as mobile cover during tactical raids. A ballistic shield's partial cover gives an attack penalty of -1 to -4, depending on the power of the weapon used. A character holding a ballistic shield has their encounter **movement rate** reduced by -50%.



[RECI]

!!!!!!!!!!!!!!!!!!!!GO GOBLIN-MODE ON SAVINGS!!!!!!!!!!!!!!!!!!!!
COME DOWN TO CRAZY BOGROOT'S MILITARY SURPLUS
JUST OFF I-69 IN BEDFORD, NEXT TO NOODLE-TROLL

6. Equipment

Utilities		
Item	Cost (gp)	Weight (in coins)
Aerial Drone	300	100
Binoculars	20	50
Bolt Cutters	10	30
Brute Force Decoder	1000	10
Canteen	1	1
Cellphone	10	2
Communications Unit	20	5
Compact Generator	50	200
Compass	5	1
Cutting Torch	100	300
Data Sensor	500	20
Directional Microphone	200	10
Environmental Scanner	50	20
Explosives Detector	150	80
Fiber Optic Camera	100	10
Fire Extinguisher	10	50
Flashlight	10	2
Gasmask	15	10
Glow Stick	1	1
Ground Drone	200	50
IR Strobe Marker	25	1
Laptop	50	20
Lighter	1	1
Metal Detector	200	100
Night Vision Goggles	500	30
Parachute	150	200
Portable Jammer	500	150
Safe Cracking Drill	1000	200
Scuba Gear	200	400
Spike Strip	50	20

Utilities (cont.)

Item	Cost (gp)	Weight (in coins)
Tactical Battering Ram	100	200
Thermal Goggles	1000	50
Tracking Device	200	1
Tool Kit	50	25
Turret Mount	1000	200
Water Purification Kit	10	10

Utilities

The following utilities are available in Modern Necessities, ranging from basics like a lighter to high-end electronics like the Brute Force Decoder.

Aerial Drone

This miniaturized Unmanned Aerial Vehicle (UAV) is outfitted with both camera and microphone, and can be flown out to 5000 feet away from the drone operator with a max speed of 200 feet, either controlled by the operator themselves, or made to follow pre-programmed GPS coordinates. Flight is sustained with small, quad rotors. Aerial Drones are relatively quiet, but anyone within 100 feet of them has a 2-in-6 chance of detecting their sound. An Aerial Drone can lift items with a weight up to 50 coins.

An Aerial Drone has an AC of 5 (14) and 1/2 HD hit points (2 hp)

Binoculars

Binoculars come in many shapes and sizes, from small folding types to large, military or survival grade variants. The average version will magnify and allow for more detailed inspection of the area or target out to 1000 feet.

Bolt Cutters

A simple tool for cutting bolts, chains, rebar and wire. Bolt Cutters are a must have item for any professional on the go.

Brute Force Decoder

This small black box filled with powerful computing technology can be attached to any computer system and initiate a brute

force hack. The character using the decoder must decide on a single hack that is performed on the system, such as disabling an alarm or gaining access to specific data. Once this single hack has been performed, the system the decoder is attached to completely shuts down. Unless specifically disabled, a brute force hack also has a 2-in-6 chance to trigger any linked security system.

Canteen

A simple canteen. Can hold 2 pints of liquid.

Cellphone

A normal portable phone. Can place calls anywhere in the world and allow access to the internet, but is also easily tracked if care is not taken.

Communications Unit

A standard radio headset or walkietalkie, allowing encrypted communications over extended distances between two or more parties. Has a range of 5 miles.

Compact Generator

This small, portable generator can put out enough juice to power simple devices for up to 24 hours on a single charge, such as a laptop. After its charge is expended, it can be recharged back to full by hooking it up to a power grid or with



solar power. This takes 2 hours when hooked to the power grid, and 6 hours with solar power.

Compass

A normal compass. Always shows true north.

Cutting Torch

Fueled by a tank of oxyacetylene that can be carried on the back, a professional cutting torch allows for the quick cutting of metal, making it rather useful for various industrial purposes as well as more nefarious applications such as defeating steel doors, safes or melting through locks. A standard steel door takes 5 minutes to cut through, and this process is highly visible. A standard lock is melted through in 20 seconds. The oxyacetylene tank has 20 charges. Each 1 minute of use consumes 1 charge.

Data Sensor

This small device detects streams of data, such as wireless transmissions, in a 20 foot radius. It does not show the exact nature of the data, just that it exists.

Directional Microphone

A pistol-like directional microphone can be pointed at an audio source out to 300 feet, allowing the user to hear a conversation and the like as if they are right there. It even works through window glass.

Environmental Scanner

This handheld device scans the air for toxins, radiation, pollutants and other anomalies.

Explosives Detector

This handheld device is capable of detecting common explosive materials in a 10 foot radius.

Fiber Optic Camera

A flexible camera wire attached to a handheld screen, it can be slipped beneath doors with sufficient gaps to see

on the other side. Creatures with vision have a 1-in-6 chance to detect the camera snooping on them.

Fire Extinguisher

This portable fire extinguisher allows the user to put out any fire in a 10 foot cube right in front of the character. A fire extinguisher has 5 charges.

Flashlight

A flashlight casts light in a 50 foot long, 10 foot wide cone.

Gasmask

Gasmasks protect against most airborne pollutants, gasses and toxins that attack the lungs, granting full immunity to these.

Glow Stick

When snapped, a glow stick casts a green light in a 15 foot radius for 1 hour.

Ground Drone

Essentially a fancy Remote Control Car, the Ground Drone is outfitted with both camera and microphone, and can be controlled out to 3000 feet from the drone operator with a max speed of 140 feet, either controlled by the operator themselves, or made to follow pre-programmed GPS coordinates. The Ground Drone is made to go over rough ground. Anyone within 100 feet of a Ground Drone has a 3-in-6 chance of detecting their sound. A Ground Drone can carry items with a weight up to 50 coins.

A ground drone has an AC of 7 (12) and 1/2 HD hit points (2 hp)

IR Strobe Marker

These small LED markers can be attached to equipment or persons, and will strobe with infrared light, only visible with infravision.

Laptop

A common laptop, allowing for portable computing power. Useful for hacking and the like.

Lighter

A simple lighter, to light things with.

Metal Detector

This handheld device can detect metal up to 10 feet in front of the user, and up to a 20 foot depth.

Night Vision Goggles

These goggles boost ambient light, allowing the user to see in the dark, albeit in green monochrome. While wearing NVG's the user has infravision out to 60 feet.

Parachute

Parachutes allow for a safe descend from great heights. Per referee's discretion, a character may require training with a parachute to use it effectively.

Portable Jammer

This device jams any incoming and outgoing signals in a 20 foot radius as long as it is powered, such as wireless connections and radio transmissions. Its own internal battery lasts 1 hour.

Safe Cracking Drill

This fully automated, powerful drill attached to a special mount can be used to drill through safe or door locks. The drill can defeat small to medium safes and normal steel doors in 10 minutes. Large vault doors take 30 minutes. This process is far from silent.

Scuba Gear

Scuba Gear allows the wearer to breath underwater for up to 2 hours, and swim at their normal movement rate. A referee may impose a depth limit.

Spike Strip

A spike strip may be deployed across the road or any other location a wheeled vehicle may pass. The vehicle's driver must make a **save vs. Paralysis** or have their vehicle's movement rate reduced by 75% until repaired.

Tactical Battering Ram

This battering ram, popular with SWAT teams, can break open a locked or stuck door with a +2 chance to the roll. This process is however quite loud.

Thermal Goggles

These goggles show the infrared spectrum, allowing the user to see in the dark, albeit in multi-color heat vision. While wearing thermal goggles the user has infravision out to 90 feet.

Tracking Device

Small devices that look like computer chips that can be hidden on a person or object and allow for the accurate tracking of movement. Their signal can be picked up by a cellphone or laptop outfitted with the tracking device's accompanying software. This signal has a range of 5 miles.

Tool Kit

A compact kit with a set of comprehensive tools to perform repairs and other mechanical related tasks.

Turret Mount

These tripods allow the mounting of firearms, from pistol size to heavy, two-handed weapons. When mounted in this way, the weapon will be automatically fired by the mount at any pre-programmed target, using a simple friend-or-foe system. They attack with **THACO 17 (+2)**. Mounted weapons are always last in initiative.

Water Purification Kit

Purifies dirty water. Each kit can purify up to 8 pints of of water in one go.



Pharmaceuticals

Item	Cost (gp)	Weight (in coins)
Antibiotics	300	2
Antidote	500	2
Bandage	5	2
Painkillers	20	2
Psychedelic Drugs	30	1
Stimulant	80	2
Tranquilizer	50	2
Truth Serum	500	2
Med Kit	100	5

Pharmaceuticals

The following medical items are available in Modern Necessities.

Antibiotics

Antibiotics can cure the effects of most common infections and diseases.

Antidote

A special serum that cures the effects of most common poisons and venoms when injected.

Bandage

A simple emergency bandage. Restores 1 hit point of damage. A character may only apply an amount of bandages equal to half their Constitution score per day.

Painkillers

These powerful painkillers restore 1d4+1 hit points of damage. Has a 10% chance of being addictive, requiring 1d4 doses daily.

Shaking off addiction requires three successful **saves vs. Poison** across the span of a week, 1 per day. A failed save causes 1 day of needing to rest. If characters press on without resting, they suffer a penalty of -1 to hit and damage rolls until they have rested for one full day.

Psychedelic Drugs

A potent psychedelic drug, such as LSD, DMT or Mescaline. A single dose will cause strong hallucinations in 1d10 minutes, making the character see things that are not there, such as monsters. In combat a character affected by these drugs will have a 3-in-6 chance of attacking a non-existent enemy. These drugs are not addictive.

Stimulant

A powerful narcotic stimulant. Temporarily restores 2d6 hit points of damage, gives a +2 bonus to saving throw rolls, and increases both Strength and Dexterity by +1 for 1 turn. Has a 30% chance to be addictive, requiring a single dose daily.

Addiction causes a -1 penalty to saving throw rolls related to sickness, disease and other health and mental related effects. Addiction also gives a -2 penalty to reaction rolls. Shaking off addiction requires four successful **saves vs. Poison** across the span of a week, 1 per day. A failed save causes 1d4 hit points of damage.

Tranquilizer

A powerful tranquilizing agent. A creature that is injected must make a **save vs. Paralysis** or be knocked out for 1 hour.



Per referee's discretion, tranquilizers may come in dart form that can be loaded in pistols or rifles. Increase cost by 3x for these.

Truth Serum

A potent concoction that will lower the inhibitions of any intelligent creature injected. Gives a +6 bonus to reaction rolls for the purpose of interacting with the affected creature.

Med Kit

A comprehensive medical kit, suitable for basic field surgery. Restores 1d6 hit points of damage. A character may only apply an amount of med kits uses equal to 1/3rd their Constitution score per day. A Med Kit has 3 uses before depletion. Also comes in a military variant at 3x cost, which restores 2d6 hit points instead.



Demolitions

Item	Cost (gp)	Weight (in coins)
Det Cord	50	100
IFF Detonator	600	5
Laser Tripwire	500	2
Remote Detonator	250	5
Timed Detonator	200	2
Mercury Switch Detonator	250	5
Motion Sensor Detonator	500	5
Tripwire	50	1
Wired Detonator	150	5

Demolitions

The following items can be paired with the explosives listed in the weapons chapter. These combinations can be used for various demolitions and boobytrap purposes.

Det Cord

Det Cord has a thin core of explosive material, and can be used to link multiple explosives together to detonate simultaneously. Det Cord comes in spools weighing 100 coins, though shorter sections may be taken.

IFF Detonator

Identification, Friend or Foe detonators can be set to only trigger when detecting unknown creatures within proximity, either through facial recognition or radio frequency tags. The identification sensor can be set to a detection distance of 1 foot to 20 feet.

Laser Tripwire

This device emits a laser across 10 feet of open space. When a creature or object steps through the beam, the attached explosive is detonated.

Lasers are only visible with Infravision, though even then they must first be located as if finding a trap. Infravision gives a +10% bonus to this roll.

Remote Detonator

Remote detonators use radio signals to transmit to a small receiver attached to the explosive, which will promptly trigger the detonation at the press of a button or switch. The remote detonator has a range of 1 mile. The detonation is instant.

Remote detonators may also be purchased as a 'Dead Man's Switch' variant, transmitting its signal when the mechanism is released rather than when it is pressed.

Timed Detonator

These detonators have a timing mechanism attached, often as simple as an electronic watch or alarm clock. The timer can be set to detonate the explosive when the time reaches 0, or when a certain hour or day is reached.

Mercury Switch Detonator

A mercury switch detonator, aka a tilt switch, is triggered upon sufficient movement, such as a vehicle pulling away.

Motion Sensor Detonator

A motion sensor detonator is triggered when, as the name implies, it senses sufficient motion nearby. The sensor can be set to a detection distance of 1 foot to 20 feet.



Tripwire

A simple piece of thin wire, such as fishing line, that when tripped will detonate the attached explosive. This is a common way to set up boobytraps using frag grenades and the like.

Wired Detonator

This detonator is directly attached to a piece of detonation cord, which in turn is attached to the explosive(s). It otherwise works the same as a remote detonator.

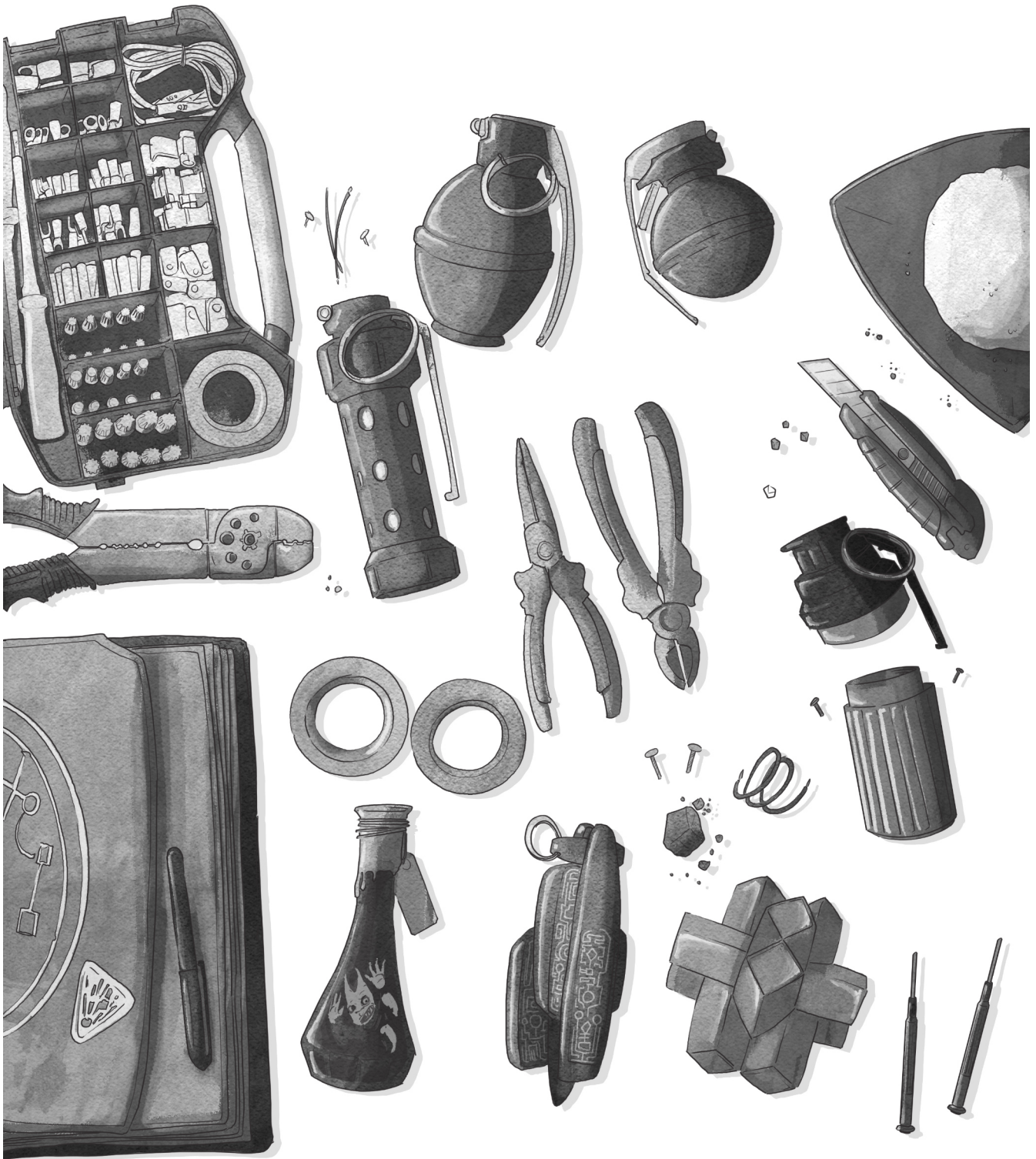

7. Vehicles

Modern vehicles in Modern Necessities have the following custom qualities, alongside some of those adapted from official material.

Armor Class (AC): Vehicles share an AC rating with characters and NPC's, and it works just the same way. When attacking a vehicle, one must meet or beat its AC to be able to do any damage. Even then, some vehicles are a tough nut to crack if the right weapon isn't used for this, as detailed below.

Hull Points (HP): Vehicles have a number of Hull Points, analogues to a character's Hit Points. Generally, every 5 points of damage from a weapon capable of damaging said vehicle translates to 1 point of hull damage. Some weapons can't even scratch a vehicle however, while others deal their full damage directly, without conversion. 5 weapon damage would be 5 hull damage.

Vulnerability Rating (VR): As noted, some vehicles are more susceptible to certain firearms than others. Each weapon has a **Vehicle Damage (VD)** number attached, listed in their own table on page 72, and which corresponds with the specific Vulnerability Rating of the vehicle, as seen with the table below.

Vulnerability Rating Table	
VR	Vulnerable To:
0	Everything. VD 1+ weapons deal direct damage.
1	VD 1+ weapons. VD 2+ weapons deal direct damage.
2	VD 2+ weapons. VD 3+ weapons deal direct damage.
3	VD 3+ weapons. VD 4+ weapons deal direct damage.
4	VD 4+ weapons. VD 5 weapons deal direct damage.

Movement Rate (MR): The first number of the vehicle's movement rate is the

maximum speed a vehicle may travel at in miles per hour. The number in the brackets behind it is the furthest distance a vehicle can travel, in feet, during a single round. Crashing a vehicle causes falling damage equal to half the movement speed at the time.

Maneuverability (MAN): The ability of the vehicle to make turns or other types of non-linear movement. This is a number subtracted from its encounter movement rate whenever the vehicle makes a maneuver such as sharp turns or avoiding an obstacle.

Fuel (F): The rate of which the vehicle consumes fuel per miles traveled. This is indicated with a number like 1/15, meaning the vehicle consumes 1 unit of fuel for every 15 miles traveled. The number in the brackets behind this is the total fuel capacity for the vehicle.

Most vehicles take gasoline, diesel or jet fuel, though some may take a different fuel type, per referee's discretion.

Cargo Capacity (CC): The maximum load the vehicle can carry, measured in coins.

Required Crew (RC): The number of people required for the vehicle's normal operation, including the manning of any mounted weapons.

Passengers (P): Some vehicles have extra space aboard specifically intended to carry passengers in addition to the normal crew. If a vehicle's description does not mention this space for passengers, it is assumed to only have space for the crew. The referee may rule that cargo hold space could be converted into additional passenger space.

Targeting passengers: With some vehicles, drivers and passengers may be targeted rather than the vehicle itself, like when firing through a windshield. In this case simply treat the vehicle as cover, giving a penalty to the attack.

Land Vehicles										
Vehicle	AC	HP	VR	TS	MAN	F	CC	RC	P	Cost (gp)
Dirt Bike	3 (16)	5	0	100 (80)	-5	1/50 (2)	500	1	1	5,000
Cruiser Bike	3 (16)	5	0	140 (100)	-10	1/40 (4)	1,000	1	1	10,000
Sports Bike	3 (16)	4	0	200 (140)	-0	1/45 (3)	200	1	1	20,000
Passenger Car	8 (11)	10	0	120 (100)	-20	1/22 (15)	5,000	1	3	10,000
Sports Car	8 (11)	12	0	180 (120)	-15	1/15 (10)	3,000	1	3	30,000
Van	9 (10)	15	0	80 (60)	-30	1/35 (20)	25,000	1	6	15,000
Pickup Truck	9 (10)	15	0	100 (80)	-30	1/30 (20)	15,000	1	5	10,000
Armored Car	9 (10)	20	2	90 (60)	-35	1/25 (15)	5,000	2	3	50,000
Semi-Truck	7 (12)	30	1	90 (60)	-50	1/10 (125)	300,000	1	25	35,000
APC	9 (10)	40	3	70 (50)	-40	1/10 (80)	150,000	3	10	200,000
Light Battle Tank	8 (11)	45	3	60 (40)	-45	1/5 (80)	20,000	3	0	1,000,000
Main Battle Tank	9 (10)	50	4	60 (40)	-50	1/3 (500)	25,000	4	0	1,500,000
Air Vehicles										
Helicopter	5 (14)	20	1	140 (200)	-10	1/7 (1200)	30,000	2	4	500,000
Attack Helicopter	5 (14)	30	3	180 (250)	-10	1/4 (1200)	15,000	2	0	2,000,000
Single Engine Plane	7 (12)	10	0	140 (200)	-15	1/15 (350)	10,000	1	3	250,000
Private Jet	9 (10)	20	1	240 (600)	-150	5/1 (3000)	200,000	2	20	1,000,000
Fighter Jet	5 (14)	20	3	500 (1300)	-50	3/1 (500)	10,000	2	0	2,500,000
Water Vehicles										
Motor Boat	7 (12)	10	0	60 (40)	-20	1/5 (100)	10,000	1	3	25,000
Assault Boat	9 (10)	30	2	40 (30)	-25	1/3 (300)	30,000	2	6	1,000,000

Vehicles

The following vehicles are available in Modern Necessities. This is of course not an entirely comprehensive list. Additional vehicles may be easily created by the referee using the rules and templates provided.

Dirt Bike

A light motorcycle made for off-road travel.

Cruiser Bike

The classic, quintessential motorcycle, popular with bike enthusiasts and outlaw bikers the world over.

Sports Bike

Made for race tracks and long stretches of road, Sport Bikes are optimized for speed and acceleration, and generally do not allow for the carrying of a passenger.

Passenger Car

Your average 4-door sedan, the most common type of car the world over.

Sports Car

These expensive cars are made for pure power and speed. This includes classic muscle cars as well as the latest super cars.

Van

A standard van, designed to transport goods and people.

Pickup Truck

A standard pick-up truck with an open cargo area. These types of vehicles are especially popular around rural areas.

In war zone areas one may encounter the 'Technical' variant, the military slang term for a pickup truck converted to a makeshift combat vehicle. Technicals often have some light armor welded on, and are outfitted with a Medium Machine Gun, Heavy Machine Gun, Grenade Launcher or Rocket Launcher mounted in its cargo bed.

Armored Car

A normal luxury car outfitted with heavy armor. Popular with VIP's around the world.

Semi-Truck

A standard cargo truck, meant to haul goods long distance. The listed cargo and passenger capacity assumes a trailer is attached.

APC

An Armored Personnel Carrier, meant to safely transport troops on the battlefield. These vehicles are usually fitted with a mounted Medium Machine Gun or Heavy Machine Gun, for protection.

Light Battle Tank

Designed to out maneuver heavier tanks, these tanks have less armor and a weaker main gun than most standard tanks, but are faster and easier to transport.

A Light Battle Tank is outfitted with a mounted Heavy Machine Gun, as well as a Main Cannon. The Main Cannon does 4d6 damage in a 15 foot radius, has a range of 300/600/900, and takes 2 rounds to reload by the gunner. It carries 30 rounds. The Main Cannon counts as a VD 4 Blast weapon.

Main Battle Tank

The standard type of tank, equipped with a heavy main gun suited to taking out other vehicles and groups of soldiers both.

A Main Battle Tank is outfitted with a mounted Heavy Machine Gun, as well as a Main Cannon. The Main Cannon does 6d6 damage in a 20 foot radius, has a range of 500/1000/1500, and takes 2 rounds to reload by the gunner. It carries 55 rounds. The Main Cannon counts as a VD 5 Blast weapon.

Helicopter

A standard civilian model helicopter, popular with news crews, police forces and rich people.

Attack Helicopter

These military helicopters are designed for high maneuverability, and are highly suited for anti-personnel purposes.

An Attack Helicopter is usually fitted with a Heavy Machine Gun as well as one or two Missile Pods. A missile pod does 6d6 damage in a 40 foot radius, and has a range of 300/600/900. It holds 16 missiles. A missile pod counts as a VD 5 Blast weapon.

Single Engine Airplane

Popular with civilian pilots and small charter flight companies, Single Engine Airplanes are useful for short to medium distance flights.

Private Jet

Popular with the rich and famous (and shady intelligence services) private jets are the epitome of luxury and discreetness, allowing people of means to travel anywhere around the world in comfort and style.

Fighter Jet

The modern Fighter Jet is a high-speed military craft suited to various purposes, from dog fighting to bombing runs.

A Fighter Jet is usually fitted with a Heavy Machine Gun and multiple heavy missiles, which can be anything from air-to-air to air-to-ground capable. A heavy missile does 10d6 damage in a 60 foot radius, and has a range of 1000/2000/3000. It carries 6 missiles. A heavy missile counts as a VD 5 Blast weapon.

Motor Boat

A standard motor boat, often used as a leisure craft or to transport (illicit) goods in shallow waters.

Assault Boat

A military assault craft often deployed as a quick reaction unit or as backup to Special Forces teams operating in aquatic areas.

An Assault Boat is usually outfitted with a mounted Heavy Machine Gun and Grenade Launcher.

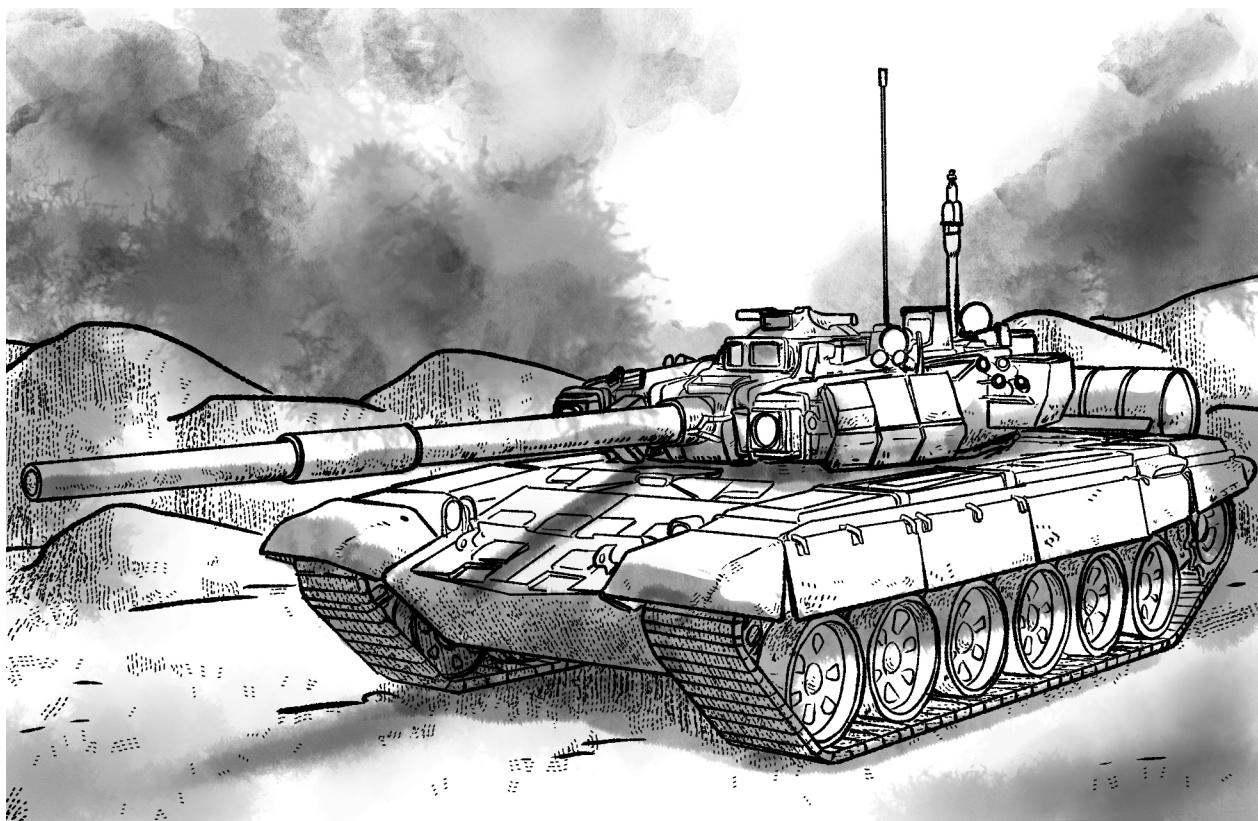



Firearms Vehicle Damage

Weapon	VD
Melee Weapons	0
Stun Gun	0
Pocket Pistol	0
Pocket Revolver	0
Pistol	0
Magnum Pistol	0
Revolver	1
Magnum Revolver	1
Sawed-Off Shotgun	0
Machine Pistol	0
Shotgun	1
Lever-Action Rifle	1
Service Rifle	2
Hunting Rifle	2
Carbine	1
Sporting Rifle	2
Big Game Rifle	3
Sub Machine Gun	1
Assault Rifle	2
Battle Rifle	2
Combat Shotgun	1
Marksman Rifle	2
Sniper Rifle	2
Light Machine Gun	2
Grenade Launcher	4
Anti-Materiel Rifle	4
Medium Machine Gun	3
Heavy Machine Gun	4
Flamethrower	1
Rocket Launcher	5
Misc light Blast weapons (grenades, landmines, etc)	3 or 4
Misc heavy Blast weapons (vehicle mounted, anti-vehicle mines, etc)	5

8. Spells

Technomancy Spells			
Spell	Spell Level	Spell	Spell Level
Ballistic Protection	1st	Camera Gun	4th
Data Wipe	1st	Cyber Zombie	4th
Finger Guns	1st	Digital Ghost	4th
Instant Message	1st	Grey Goo	4th
Magic Battery	1st	Holographic Decoy	4th
Nano Repair	1st	Living Tool Kit	4th
Nitro Boost	1st	Magic Road	4th
System Security	1st	Weapons Room	4th
Electric Surge	2nd	Anti-Tech Shell	5th
Extract Data	2nd	Artillery Strike	5th
Ghost Rider	2nd	Blackout	5th
Magnetic Shield	2nd	Electric Eye	5th
Mind and Machine	2nd	Invisible Paint	5th
Nano Heal	2nd	Magnetic Pull	5th
Suppress Alarms	2nd	Virtual Reality	5th
Weaken Firewall	2nd	Wire Transfer	5th
Backdoor	3rd	Android	6th
Blast Protection	3rd	Dimension Road	6th
Collect Call	3rd	Energy Transfer	6th
Conjure Ammo	3rd	Force Field	6th
Counter Surveillance	3rd	Infinite Ammo	6th
Detect Surveillance	3rd	Magic Gun	6th
EMP	3rd	Pocket Vault	6th
Leg Room	3rd	Radiation Leak	6th

Technomancy Spells

Modern Necessities adds a new type of magic called Technomancy. Technomancy comes with the following spells. Some of these can be used at higher levels, as described.

Level 1 Technomancy

Ballistic Protection

- **Duration:** 8 hours
- **Range:** The caster or a creature touched

A selected creature gains +1 AC and +1 to death save rolls against firearms for the duration per level of the spell. This does not apply to firearms with the Blast or Splash quality.

Data Wipe

- **Duration:** Instant
- **Range:** A touched device

Completely wipe the data from a single computing or data storage device, such as a laptop or USB stick.

Finger Guns

- **Duration:** 12 hours
- **Range:** The caster

The caster gains the ability to fire phantom bullets from their finger when holding their hand in the shape of a gun and loudly saying 'Pew!'. This finger gun does 1d6 damage and has a range of 40/80/120. It does not require reloads. The damage is increased by +1 per level of the spell.

Instant Message

- **Duration:** Instant
- **Range:** The caster

The caster instantly and hands free sends a text message, up to 25 words long, to a

chosen recipient with a device capable of receiving the message. The caster must know the recipient.

Magic Battery

- **Duration:** 4 hours
- **Range:** A touched device

A selected electronic device becomes fully powered for the duration.

Nano Repair

- **Duration:** Instant
- **Range:** A touched device

A single, small to medium sized mundane technological object is repaired to full instantly by a cloud of nano bots. Objects that can be repaired include radios, small generators, computers, etc.

Nitro Boost

- **Duration:** 12 hours
- **Range:** A touched vehicle

A selected vehicle has their movement rate increased by 25% for the duration.

System Security

- **Duration:** Permanent
- **Range:** A touched device

A selected computing gains a magically enhanced firewall. Any attempts to hack the device are taken with a -10% penalty per level of the spell.

Level 2 Technomancy

Electric Surge

- **Duration:** Instant
- **Range:** 60 feet

The caster unleashes a bolt of electricity from their fingertips at a single target within range. The bolt deals 1d6 damage per level of the caster, with a successful



save vs. Spells indicating half damage. The bolt also has a 2-in-6 chance to disrupt electronic devices carried by the target, causing them to malfunction or shut down for 1d4 rounds.

Extract Data

- **Duration:** Instant
- **Range:** A touched device

Extract the data from the touched storage device, transferring it to another device owned by the caster. This also copies any encryption and other security measures on the touched device itself.

Ghost Rider

- **Duration:** 12 hours per level
- **Range:** 60 feet

The caster summons a phantom vehicle at a point within range. The vehicle has the same stats as either a Cruiser Bike or Passenger Car, though will look faintly supernatural or futuristic in some way.

Magnetic Shield

- **Duration:** 2 turns
- **Range:** The caster

The caster is surrounded by a bubble of magnetism of sufficient power to deflect small metal objects. When successfully hit with a metal weapon or metal projectile, the attack has a 3-in-6 chance of missing anyway.

Mind and Machine

- **Duration:** 2 turns per level
- **Range:** 60 feet

The caster can control and manipulate any electronic or mechanical device within range that they would normally be able to control by touch as well. The caster can turn devices on or off, alter their settings, or even attempt to make them malfunction. The more complex the device, the more difficult it is to control, and some devices may be completely immune to this spell, per referee's

discretion.

Nano Heal

- **Duration:** 4 turns
- **Range:** The caster or a creature touched

The caster unleashes a cloud of nanobots that gradually heal the target's minor injuries at a molecular level. The nanobots restore 1d4 hit points of damage every turn. When a creature hits 0 hit points the nanobots become inactive.

Suppress Alarms

- **Duration:** 1 turn
- **Range:** The caster

Temporarily suppresses any alarm system within 15 feet around the caster.

Weaken Firewall

- **Duration:** 1 turn
- **Range:** A touched device

Magically weaken a computing device's firewall. Any attempts to hack the device are taken with a +5% bonus for the duration per level of the spell.

Level 3 Technomancy

Backdoor

- **Duration:** Instant
- **Range:** A touched device

The caster may leave a backdoor inside a system that was already successfully hacked previously. This allows them renewed access to the system at any point of their choosing, even after security has been restored, as long as they can access it directly or through a network. This access is undetectable.



Blast Protection

- **Duration:** 8 hours
- **Range:** The caster or a creature touched

A selected creature gains damage reduction against weapons with the Blast quality equal to one die of damage per level of the spell. For example, a grenade that would do 4d6 damage only does 3d6 when 3rd level Blast Protection is active.

Collect Call

- **Duration:** 24 hours
- **Range:** The caster

The caster may contact an intelligent creature they have previously communicated with. The contacted creature will hear any telephone within 200 feet of them begin to ring incessantly for the duration until they answer and speak to the caster. This call can not be listened in on or tracked by 3rd parties.

Conjure Ammo

- **Duration:** Instant
- **Range:** 30 feet

The caster conjures a small pile of common bullet or shotgun ammunition at a point within range. The pile has 2d6 reloads worth of said ammunition.

Counter Surveillance

- **Duration:** 6 turns
- **Range:** The caster

The caster and any friendly creature within 15 feet of them becomes partially obscured when recorded by non-magical audio and visual devices such as cameras and microphones. Facial features are pixelated and audio only picks up white noise.

Detect Surveillance

- **Duration:** Instant
- **Range:** The caster

The caster immediately becomes aware of any electronic surveillance conducted upon them up to a distance of 500 feet. This includes hidden cameras, directional microphones, tracking devices, etc.

EMP

- **Duration:** Instant
- **Range:** 80 feet

Causes a powerful electromagnetic pulse at a point within range. Any unshielded electronic device within a 20 foot radius of that point is immediately damaged and shut down.

Leg Room

- **Duration:** 24 hours
- **Range:** A touched vehicle

A vehicle the caster touches becomes capable of holding double the amount of passengers as is normal, or capable of carrying +50% more coins. Choose one.

Level 4 Technomancy

Camera Gun

- **Duration:** 1 turn
- **Range:** A touched device

The caster can use a single camera they have access to as a gun, capable of targeting creatures in view. This applies to cameras in a network the caster has access to as well, such as security cameras. The camera gun does 2d6 damage and has a range of 60/120/180. It does not require reloads.



Cyber Zombie

- **Duration:** Permanent
- **Range:** A touched dead creature

The caster touches the corpse of a recently deceased creature, dead no more than a day and no bigger than a human. Special nanobots bring the creature back to life as a cyber zombie under the caster's control. This cyber zombie has the statistics of the standard Zombie listed in core materials, but with Hit Dice equal to the level of the spell instead. The cyber zombie is capable of wielding firearms.

Digital Ghost

- **Duration:** Indefinite
- **Range:** A touched device

The caster's spirit leaves their body to mentally inhabit a computing device of their choice. When inside the device, they have full control of any unsecured part of it. Secured parts meanwhile can be hacked with a +30% bonus to the roll. The caster can willingly leave the system to return to their body at any point, as long as their body remains within at least 50 feet of the device.

Should the device be destroyed, the caster makes a **save vs. Death** or takes 4d6 damage to their body as their mind is violently thrown back into it. The caster may **save vs. Paralysis** to escape into another part of a network or the internet as a whole to avoid this fate. In this case they will need to find another device in proximity to their body to successfully return to it.

While a digital ghost, physical bodies left behind are vulnerable and defenseless.

Grey Goo

- **Duration:** 4 turns
- **Range:** 30 feet

The caster unleashes a cloud of hungry nanobots at point within range. Any stationary electronic or mechanical device within 30 feet of that point, up to

the size of a passenger car, is consumed by the nanobots until nothing but a grey goo remains. Devices carried by creatures are unaffected unless the creature remains within the affected area for more than 1 turn.

Holographic Decoy

- **Duration:** 1 hour per level
- **Range:** 100 feet

The caster creates a holographic duplicate of themselves that appears at a point within range. The duplicate is a perfect copy of the caster in every way and can move and speak like the caster. The duplicate can be commanded by the caster to appear to perform specific actions or follow specific instructions. The duplicate must be touched for others to realize it is only a fake.

If the decoy is hit by an attack, it makes a **save vs. Death** with a score equal to the caster to avoid being destroyed. If the saving throw is failed, the decoy dissipates and the spell ends. The caster must stay within 500 feet of the decoy for it to remain active.

Living Tool Kit

- **Duration:** Permanent
- **Range:** The caster or a creature touched

A selected creature absorbs an item of their choice from the equipment chapter into their own body. They permanently have immediate access to and every benefit of the piece of equipment. A creature can only absorb an amount of items equal to 1/3rd their level, to a minimum of 1.

Magic Road

- **Duration:** 2 hours per level
- **Range:** A touched vehicle

The caster touches a land vehicle, causing a magic road to manifest beneath it for the duration. This road bypasses any difficult terrain that would normally slow down the vehicle.



Weapons Room

- **Duration:** Instant
- **Range:** The caster

The caster opens an unlocked door of their choice to a special pocket dimension. This dimension appears as a blank, white room filled with racks of melee weapons, as well as light and medium firearms of the referee's choice. Each character in the caster's party may select one of these weapons. The room disappears after use. Nothing new can be stored in the room.

Level 5 Technomancy

Anti-Tech Shell

- **Duration:** 1 turn
- **Range:** The caster

The caster surrounds themselves with a shimmering bubble of technology rejecting energy, out to a radius of 15 feet. Any sufficiently technological item is unable to pass the bubble. Creatures carrying these items are unable to pass as well. Common projectiles such as bullets may still pass, however.

Artillery Strike

- **Duration:** Instant
- **Range:** 500 feet

The caster drops an artillery (arcane artillery) strike at a point within range. Creatures 5 HD or more that are within 20 feet of the point of impact **save vs. Death** or take 5d6 damage. Creatures below 5 HD **save vs. Death** or are simply obliterated. An artillery strike requires an open sky.

Blackout

- **Duration:** 1 turn
- **Range:** The caster

The caster instantly snuffs out any light source in a 500 foot radius, for the

duration. This includes natural, electrical, chemical and magical light sources.

Electric Eye

- **Duration:** 24 hours
- **Range:** The caster

The caster transfers their consciousness into a spy satellite high in earth orbit. From there they may perform careful surveillance upon locations of their choice, as long as the satellite is above the right area of the planet. This surveillance allows them to gain highly detailed information of the target area, per referee's discretion.

While in the satellite, physical bodies left behind are vulnerable and defenseless.

Invisible Paint

- **Duration:** 8 hours
- **Range:** A device or vehicle touched

The caster touches a mechanical object of their choice, turning it invisible to the naked eye for the duration. The object can be no larger than a battle tank. Creatures with infravision have a 1-in-6 chance to still spot the object.

Magnetic Pull

- **Duration:** Instant
- **Range:** 80 feet

The caster creates a strong magnetic pull at a point within range. Any metal object within 40 feet of the point, up to the size of a passenger car, is instantly pulled to the center to smash together. This includes creatures carrying sufficient metallic objects that they can not let go. Affected creatures **save vs. Spells** or take falling damage as if they fell double the distance they were pulled, plus an additional 2d6 of damage.

Creatures that make their save manage to stand their ground or find something to hold on to.



Virtual Reality

- **Duration:** Indefinite
- **Range:** The caster or a creature touched

The caster creates a virtual environment of their choice, only distinguishable as fake by themselves and those they wish to know. Others that are somehow pulled in are fully immersed in this virtual environment, experiencing it as if it were real. For every 1 day that passes in real time, 1 week passes in the virtual environment.

While in the virtual world, physical bodies left behind are vulnerable and defenseless. Characters that know the environment is fake can choose to leave at any time.

Wire Transfer

- **Duration:** Instant
- **Range:** A touched device

The caster can use any networked device they touch to instantly teleport outside another device in the same network that they are aware of. The network has no size or distance limit.

Level 6 Technomancy

Android

- **Duration:** Permanent
- **Range:** A touched dead creature

The caster touches the corpse of a recently deceased creature, dead no more than a day and no bigger than a human. Special nanobots bring the creature back to life as an advanced android with the exact memories and personality of the deceased creature. This android body functions largely as normal, though has some obvious differences, such as mechanical looking eyes or unnatural skin. It is also vulnerable to any effects that would damage technology, such as EMP blast.

Dimension Road

- **Duration:** Instant
- **Range:** A touched vehicle

The caster touches a land vehicle, giving it the ability to travel between dimensions, to emerge at a point of the caster's choice. This is a one way trip until the spell can be cast again.

Energy Transfer

- **Duration:** Instant
- **Range:** 30 feet

The caster drains and stores the energy powering an object of their choice within range. Small to medium sized objects may be drained completely, ceasing their function. Larger objects may only be temporarily weakened.

The caster can choose to unleash the drained energy in the following ways. This must be done within 1 turn.

Transfer: The caster transfers the energy to a device of the same or smaller size, powering it.

Electric Surge: The caster unleashes an Electric Surge spell at 6th level.

Restore Life: The caster's touch heals a creature for 2d6 hit points of damage.

Defibrillator: The caster's touch attempts to restart a recently deceased character's heart. This has a 4-in-6 chance to bring a dead character back to life if they have been dead for no more than a minute (and their body is reasonably intact), bringing them back to 1 hit point.

Force Field

- **Duration:** 6 turns
- **Range:** The caster

The caster surrounds themselves with a bubble of impenetrable energy, out to a radius of 25 feet. This bubble can not be penetrated by any physical matter or



energy, including magical, though it may let in fresh air. This applies to anything trying to go out of the bubble as well.

Infinite Ammo

- **Duration:** Permanent
- **Range:** Firearm touched

The caster touches a personal firearm (light, medium or heavy) and gives it the ability to never run out of mundane bullets, negating the reload quality unless special ammo is used. The caster may only apply this to an amount of firearms equal to their Intelligence modifier at one time.

Magic Gun

- **Duration:** Permanent
- **Range:** Firearm touched

The caster touches a personal firearm (light, medium or heavy) and makes it a +1 weapon. This can be repeated multiple times on the same gun up to a maximum of +3. The weapon counts as magical, no matter what ammo type is used.

Pocket Vault

- **Duration:** Instant
- **Range:** The caster

The caster opens an unlocked door of their choice to a special pocket dimension. This dimension appears as standard concrete and steel bank vault, 40 x 40 feet big. This space can be used to safely store items and valuables. Only the caster and creatures of their choice may enter the vault. Its exact location can never be discovered by 3rd parties.

Radiation Leak

- **Duration:** 1 turn
- **Range:** The caster

The caster emits a deadly field of radiation out to 100 feet. Any unprotected creature caught in the radiation takes 1d4 hit points of damage per round. Creatures below 5 HD save vs. **Death**

every round of contact with the radiation, or they will die within 1d6+1 days unless cured.





9. NPC's

The following NPC's are available in Modern Necessities for characters to encounter on their adventures. These are meant to offer a basic spread of modern themed enemies and allies, rather than an entirely comprehensive list of the many types of foes one may encounter in a given setting.

Behemoth

A large, heavily armored soldier wearing a modified bomb suit and carrying heavy weapons.

- **Armor Class:** 2 [17]
- **Hit Dice:** 5 (23hp)
- **Attacks:** 1 x Weapon
- **Common Weapons:** Sledge Hammer, Magnum Pistol, Medium Machine Gun, Grenade Launcher
- **THAC0:** 15 (+4)
- **Movement:** 90' (30')
- **Saving Throws:** D10 W11 P12 B13 S14
- **Morale:** 12
- **Alignment:** Any, usually Neutral
- **XP:** 125
- **Number Appearing:** 1d2
- **Treasure:** Type B
- **Damage Reduction:** Half damage from mundane weapons/ammunition (Blast weapons excluded).
- **Blast Resistant:** +6 bonus to save vs. Death rolls against Blast weapons.

Commando

A member of a Special Forces unit. Highly trained and with official military support.

- **Armor Class:** 3 [16]
- **Hit Dice:** 4 (18hp)
- **Attacks:** 2 x Weapon
- **Common Weapons:** Combat Knife, Pistol, Assault Rifle, Battle Rifle, Combat Shotgun, Light Machine Gun, Medium Machine Gun, Frag Grenade, Flash Grenade, Plastic Explosives
- **THAC0:** 16 (+3)
- **Movement:** 120' (40')
- **Saving Throws:** D10 W11 P12 B13 S14
- **Morale:** 12
- **Alignment:** Any, usually Lawful
- **XP:** 125
- **Number Appearing:** 1d4 (2d4)
- **Treasure:** Type B
- **Squad Leader:** The squad leader gains a +2 bonus to damage rolls.
- **Ambush:** Will use ambush tactics to gain surprise.
- **Air Support:** Can call in a strike on enemy positions once per combat encounter. Requires open sky. Strike will be deployed in 6 + 1d4 rounds. Can deploy the following options.
- **Drone Strike:** 6d6 damage, 40 foot radius.
- **Strafing Run:** 3d6 damage, 60 foot long and 10 foot wide area.



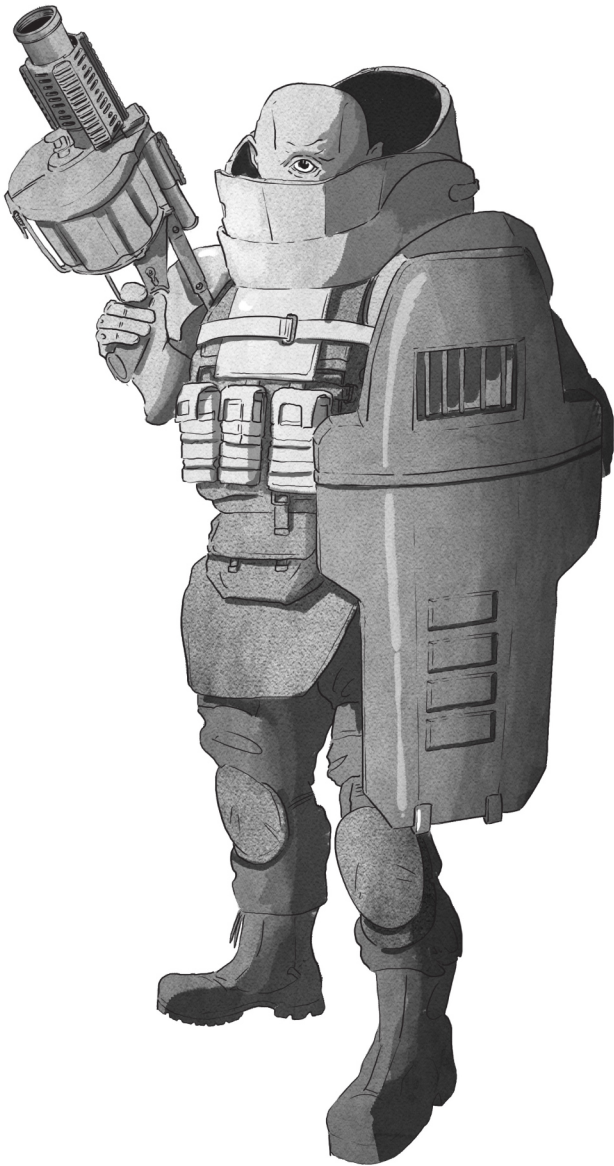

Cybercriminal

A hacker that has turned to a life of computer crime.

- **Armor Class:** 9 [10]
- **Hit Dice:** 1/2 (2hp)
- **Attacks:** 1 x Weapon
- **Common Weapons:** Pocket Pistol, Pocket Revolver
- **THAC0:** 20 (-1)
- **Movement:** 120' (40')
- **Saving Throws:** D13 W14 P13 B16 S15

- **Morale:** 4
- **Alignment:** Chaotic
- **XP:** 5
- **Number Appearing:** 1
- **Treasure:** Type T
- **1337:** Has hacking skill and casts Technomancy spells as a level 2 + 1d4 Tech Expert (roll for exact level).

Detective

A private eye or police detective, such as those that investigate homicides and robberies.

- **Armor Class:** 7 [12]
- **Hit Dice:** 2 (9hp)
- **Attacks:** 1 x Weapon
- **Common Weapons:** Magnum Revolver, Shotgun
- **THAC0:** 18 (+1)
- **Movement:** 120' (40')
- **Saving Throws:** D12 W13 P14 B15 S16
- **Morale:** 10
- **Alignment:** Lawful
- **XP:** 30
- **Number Appearing:** 1d2
- **Treasure:** Type T
- **Sleuth:** Will pursue characters responsible for a crime, or otherwise being investigated, relentlessly. Will track down clues to discover their whereabouts.
- **Backup:** Will often bring backup into combat, such as Police Officers and SWAT officers.
- **Do You Feel Lucky?:** +1 damage against chaotic/criminal characters.

Drone Dog

A robotic, AI powered canine adapted to military or security purposes. It has a firearm mounted on its armored frame.

- **Armor Class:** 4 [15]
- **Hit Dice:** 5 (23hp)
- **Attacks:** 1 x Weapon or 1 x Pounce (1d6)
- **Common Weapons:** Combat Shotgun, Sub Machine Gun, Assault Rifle
- **THAC0:** 14 (+5)
- **Movement:** 240' (80')
- **Saving Throws:** D10 W11 P12 B13 S14
- **Morale:** 12
- **Alignment:** Neutral
- **XP:** 20
- **Number Appearing:** 1d4
- **Treasure:** None
- **Infravision:** 90'
- **Damage Reduction:** Half damage from mundane weapons/ammunition (Blast weapons excluded).
- **Blast Resistant:** +4 bonus to **save vs. Death** rolls against Blast weapons.
- **Robot:** Make no noise, until they attack. Immune to effects that affect living creatures (e.g. poison). Immune to mind-affecting or mind-reading spells (e.g. charm, hold, sleep).
- **Surprise:** On a 1 - 5, due to AI calculating the best way to ambush.
- **Pursuit:** Will pursue relentlessly, unless called off.
- **Pounce:** Jump forward 30 feet and gain +1 to attack

Enforcer

Tough criminal guards and right-hand men.

- **Armor Class:** 5 [14]
- **Hit Dice:** 2 (9hp)
- **Attacks:** 1 x Weapon
- **Common Weapons:** Brass Knuckles, Baseball Bat, Magnum Pistol, Magnum Revolver, Shotgun
- **THAC0:** 18 (+1)
- **Movement:** 120' (40')
- **Saving Throws:** D12 W13 P14 B15 S16
- **Morale:** 8
- **Alignment:** Chaotic
- **XP:** 20
- **Number Appearing:** 1d2
- **Treasure:** Type V

Hitman

Professional killers for hire.

- **Armor Class:** 5 [14]
- **Hit Dice:** 3 (13hp)
- **Attacks:** 2 x Weapon
- **Common Weapons:** Straight Razor, Suppressed Pistol
- **THAC0:** 17 (+2)
- **Movement:** 120' (40')
- **Saving Throws:** D13 W14 P13 B16 S15
- **Morale:** 8
- **Alignment:** Neutral
- **XP:** 50
- **Number Appearing:** 1
- **Treasure:** Type V



- **Assassinate:** 2x damage on unaware targets



Hunter

Professional hunters and trackers. Some prefer the thrill of two legged prey.

- **Armor Class:** 5 [14]
- **Hit Dice:** 3 (13hp)
- **Attacks:** 1 x Weapon
- **Common Weapons:** Machete, Magnum Revolver, Hunting Rifle, Big Game Rifle
- **THAC0:** 17 (+2)
- **Movement:** 120' (40')
- **Saving Throws:** D14 W15 P16 B17 S18
- **Morale:** 12
- **Alignment:** Neutral
- **XP:** 50
- **Number Appearing:** 1
- **Treasure:** Type K
- **Tracker:** Will pursue relentlessly. Pursued creatures have a -20% to evasion rolls.
- **Hunter:** +1 damage to chosen prey (choose type, such as beasts or humanoids).

Mercenary

A professional soldier of fortune, heavily armed and well trained.

- **Armor Class:** 4 [15]
- **Hit Dice:** 3 (13hp)
- **Attacks:** 2 x Weapon
- **Common Weapons:** Combat Knife, Pistol, Assault Rifle, Combat Shotgun, Light Machine Gun, Frag Grenade
- **THAC0:** 17 (+2)
- **Movement:** 120' (40')

- **Saving Throws:** D12 W13 P14 B15 S164
- **Morale:** 10
- **Alignment:** Any, usually Neutral
- **XP:** 50
- **Number Appearing:** 1d6 (2d6)
- **Treasure:** Type B
- **Squad Leader:** The squad leader gains a +1 bonus to damage rolls.
- **Ambush:** Will use ambush tactics to gain surprise.

Mobster

An important, high-ranking gangster, such as a mafia made man.

- **Armor Class:** 7 [12]
- **Hit Dice:** 2 (9hp)
- **Attacks:** 1 x Weapon
- **Common Weapons:** Brass Knuckles, Straight Razor, Magnum Pistol, Magnum Revolver, Shotgun, Sub Machine Gun
- **THAC0:** 18 (+1)
- **Movement:** 120' (40')
- **Saving Throws:** D12 W13 P14 B15 S16
- **Morale:** 10
- **Alignment:** Chaotic
- **XP:** 20
- **Number Appearing:** 1
- **Treasure:** Type I (Type G for Capo)
- **Lair:** Will own a place where they conduct their criminal business, such as a gentleman's club.
- **Crew:** Runs a crew of lower-rank criminals. Crew consists of 1d8 Thugs, 1d6 Mooks, 1d4 Enforcers and 1d2 Hitmen. Double the amount for a

Capo.

- **Capo:** Has a 1-in-6 chance to be a 4 HD (18hp) Capo instead.

Mook

Professional criminals. Usually working as henchmen.

- **Armor Class:** 7 [12]
- **Hit Dice:** 1 (4hp)
- **Attacks:** 1 x Weapon
- **Common Weapons:** Pistol, Revolver
- **THAC0:** 19 (0)
- **Movement:** 120' (40')
- **Saving Throws:** D12 W13 P14 B15 S16
- **Morale:** 8
- **Alignment:** Chaotic
- **XP:** 10
- **Number Appearing:** 1d4
- **Treasure:** Type U

Operative

An elite government spy or assassin, highly trained in stealth missions.

- **Armor Class:** 7 [12]
- **Hit Dice:** 4 (18hp)
- **Attacks:** 2 x Weapon
- **Common Weapons:** Combat Knife, Ninjato, Suppressed Pistol, Suppressed Sub Machine Gun, Suppressed Assault Rifle, Flash Grenade
- **THAC0:** 16 (+3)
- **Movement:** 120' (40')
- **Saving Throws:** D13 W14 P13 B16 S15



- **Morale:** 10
- **Alignment:** Any, usually Lawful
- **XP:** 125
- **Number Appearing:** 1d2
- **Treasure:** Type B
- **Assassinate:** 2x damage on unaware targets
- **Surprise:** On a 1 - 4, due to stealth skills. +4 to hit on first attack with a successful surprise. Must be within weapon's close range for this.
- **Stealthy:** Can move silently with a 60% chance. Has a 50% chance to hide in shadows.

Police Officer

A normal street cop.

- **Armor Class:** 7 [12]
- **Hit Dice:** 1 (9hp)
- **Attacks:** 1 x Weapon or 1 x Arrest
- **Common Weapons:** Pistol, Stun Gun, Shotgun
- **THAC0:** 19 (+0)
- **Movement:** 120' (40')
- **Saving Throws:** D12 W13 P14 B15 S16
- **Morale:** 8
- **Alignment:** Any, usually Lawful
- **XP:** 13
- **Number Appearing:** 1d6
- **Treasure:** Type S
- **Arrest:** Can attempt to grab and hold target. This attack is made at THAC0 20 (-1). If initial hold is successful, may attempt to handcuff target on their next round with another arrest attack. Handcuffed target is unable to perform most actions requiring the

use of hands until handcuffs are removed. **Save vs. Paralysis** resists both attempts.

SWAT Officer

A highly trained police over that is a member of a special tactical unit.

- **Armor Class:** 5 [14]
- **Hit Dice:** 3 (13hp)
- **Attacks:** 2 x Weapon or 1 x Arrest
- **Common Weapons:** Pistol, Sub Machine Gun, Shotgun, Flash Bang Grenade, Tear Gas Grenade
- **THAC0:** 17 (+2)
- **Movement:** 120' (40')
- **Saving Throws:** D12 W13 P14 B15 S16
- **Morale:** 12
- **Alignment:** Any, usually Lawful
- **XP:** 50
- **Number Appearing:** 1d8
- **Treasure:** Type V
- **Arrest:** Can attempt to grab and hold target. This attack is made at THAC0 18 (+1). If initial hold is successful, may attempt to handcuff target on their next round with another arrest attack. Handcuffed target is unable to perform most actions requiring the use of hands until handcuffs are removed. **Save vs. Paralysis** resists both attempts.

Sharpshooter

A military trained marksman or sniper.

- **Armor Class:** 5 [14]
- **Hit Dice:** 3 (13hp)
- **Attacks:** 1 x Weapon



- **Common Weapons:** Combat Knife, Pistol, Marksman Rifle, Sniper Rifle, Anti-Materiel Rifle, Smoke Grenade
- **THAC0:** 15 (+4)
- **Movement:** 120' (40')
- **Saving Throws:** D12 W13 P14 B15 S16
- **Morale:** 10
- **Alignment:** Any, usually Neutral
- **XP:** 100
- **Number Appearing:** 1 (1d2)
- **Treasure:** Type B
- **Dead Eye:** Has better than average accuracy (reflected in THAC0 score).
- **Ambush:** Will use ambush tactics to gain surprise. +1 to damage on successful surprise.
- **Fire From Concealment:** Has a 35% chance to stay hidden when firing from concealment. Every subsequent shot decreases this chance by -10%. They must be using a weapon with the Sniper property and be firing from medium range or long range. A suppressor reduces the penalty to -5%.

Thug

Average low level criminal.

- **Armor Class:** 9 [10]
- **Hit Dice:** 1/2 (2hp)
- **Attacks:** 1 x Weapon
- **Common Weapons:** Pocket Pistol, Pocket Revolver
- **THAC0:** 20 (-1)
- **Movement:** 120' (40')
- **Saving Throws:** D14 W15 P16 B17 S18
- **Morale:** 6
- **Alignment:** Chaotic
- **XP:** 5
- **Number Appearing:** 1d4
- **Treasure:** Type T



10. Extra Rules

Damage Multiplier

This optional rule simulates the chance of different areas of the body being hit, resulting in different levels of damage being taken by the target when a character scores a critical hit (if a critical hit rule is used).

With this rule in place, a headshot will do more damage than a hit to one of the limbs, for example. For roleplaying purposes, this method simulates the attack hitting a particularly vulnerable area, such as piercing an organ or slicing a main artery.

To achieve this multiplier, the character making the attack rolls another d20 right after rolling a natural 20 on their attack roll, and consults the table below to see which area of the target's body was hit. The inflicted damage is then multiplied by the listed amount.

Note that these multipliers do not apply to Blast damage. Also note that these multipliers assume a humanoid opponent. For opponents with a different physical makeup, another sort of vulnerable area or special damaging effect can be described.

Damage Multiplier Table		
D20 Roll	Area Hit	Multiplier
1 - 2	Leg	x1.5
3 - 5	Arm	x1.5
6 - 9	Groin	x2
10 - 13	Stomach	x3
14 - 17	Chest	x4
18 - 20	Head	x5

Per referee's discretion, the weapon or caliber used, as well as armor worn, cover taken and even certain magical effects may reduce these multipliers. For example, a kevlar vest may reduce the

multiplier for stomach and chest shots by -1 or even -2 when a pistol is used.

Cinematic Mode

This optional mode of play allows characters to be considerably more powerful than normal. This type of play is perfect for those referee's wishing to run their campaigns with an increased action movie-like feel, letting characters dodge bullets while they gun down mooks to their heart's content. As such, Cinematic Mode is also a great choice for characters running solo, or those operating with a smaller than normal group.

Cinematic Mode offers the following options. These can be mixed and matched to the referee's wishes.

Increased Health: Characters using Cinematic Mode gain their maximum Hit Points with each level.

Hard To Hit: Characters using Cinematic Mode gain a permanent +1 or +2 bonus to AC.

Mook Killer: Instead of targeting a creature's health like normal, any damage by the character to an enemy may be dealt directly to their Hit Dice instead after being properly converted, reducing their HD directly by that number. This allows for potentially much faster kills. The conversion is as follows.

The referee may deem some attacks, such as those made with powerful Blast weapons, to still deal damage as normal.

Damage Conversion Table	
Normal Damage	HD/Hero Damage
1	No Damage
2 - 5	1
6 - 9	2
9 - 12	3
13+	4



Hero Damage: The characters take less damage, based on the same conversion table. For example, a character taking 13 damage would only lose 4 hit points instead, after conversion.

Overkill: Per referee's discretion, any damage rolled in excess of what is required to kill the targeted creature may be applied to another creature nearby, if the situation is deemed to make sense. For example, this may simulate a quick double tap to two guards standing shoulder to shoulder, or a sweep of a sub machine gun taking out a whole bunch of mooks in one go.

Firearm Jamming

Some referees might want to add additional realism by adding a jamming mechanic to firearms. This rule offers a simple method for handling this by forcing the character shooting a firearm to roll an additional d6 if they were unlucky enough to roll a natural 1 on their firearm attack, to simulate the chance of their firearm getting jammed.

Single shot weapons have a 2-in-6 chance to jam. Weapons fired in Auto Fire mode or those like the Flamethrower have a 4-in-6 chance to jam. It takes a character a full round to clear a jam, though they may switch to a different weapon instead.

Armor Damage

Some referees might wish for armor to become ineffective after a few shots, its protective quality whittled down by taking repeated hits. The way this is simulated is by optionally giving armor its own 'HP' pool, hence forth known as Armor Points (AP).

A successful attack will damage armor for half the amount of damage rolled. When AP reaches 0, the armor must be replaced or repaired, in the meantime dropping the character's AC by -4 (-3), to a minimum of 9 (10). If a shield is destroyed the character simply loses their additional AC bonus from the shield instead.

If a character is actively using a shield, any damage will affect the shield before it does the armor they are wearing. Referees may also deem some attacks making armor irreparable.

AP is calculated as follows, per armor type. This uses the ascending AC numbers even if descending is otherwise used in the game.

- **Light Armor:** Equal to AC.
- **Heavy Armor:** Equal to AC + Half. Exo Armor may have 2x, per referee's discretion.

Multi-Attacks

Referees may allow characters to gain additional attacks as they level up. The table below gives the suggested extra attacks gained at certain levels for each Modern Necessities class.

Multi-Attack Table	
Class	Extra Attack Gained at Level
Soldier	Level 3, 6, 9
Heavy Gunner	Level 3, 6, 9
Crook	Level 4, 8
Tech Expert	Level 4
Sniper	Level 3, 6, 9
Survivalist	Level 4, 8
Hired Killer	Level 4, 8
Medic	Level 4
Psychonaut	Level 4
Wheelman	Level 4
Ninja	Level 3, 6, 9
Exorcist	Level 3, 6, 9
Face	Level 4

Bleeding

This optional rule adds additional lethality by adding the potential to bleed out from injury. A creature that is successfully hit by an attack capable of causing severe bleeding makes a **save vs. Death**. A successful save means they take damage like normal. A failed save however means the attack was sufficient to perhaps mortally wound them, at which point they start taking damage every round equal to half the weapon's listed damage, rolled that round, as they begin to bleed out.

If a creature failed their save and takes damage equal to half their Hit Points or more, either from the initial attack or from bleeding out, the referee may call for a **save vs. Paralysis**. On a fail the creature falls unconscious.

Per referee's discretion, a creature may suffer from multiple bleed effects at once.

Bleeding can be staunched with medical items and healing magic of the referee's choice.

Session XP

Some referees may want to use a different advancement system than the one presented in the core OSE rules, simply because it doesn't make as much sense for their campaign. There may be no expectation to find any treasure for example, the campaign instead being mission based.

The table included with this rule presents a session based XP progression system instead. Generally, a character will receive +1 XP for every session of play that is completed. Though of course referees may award more for good roleplay, successfully completing side missions, or whatever else they deem proper.

Take note that with this system, characters will level at a more equal pace as well.

Session XP Table	
Level	XP Required
1	0
2	3
3	6
4	10
5	15
6	20
7	30
8	40
9	50
10	60
11	70
12	80
13	90
14	100

